

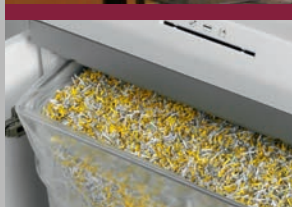

MARTIN YALE  
Industries

Catalog  
1/2012

www.martinyale.com



Professional  
Data Shredders



Solution for  
Sustainable  
Waste Management

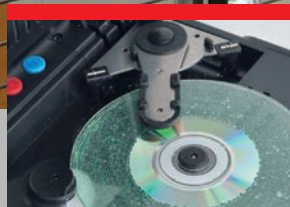

Multi Media  
Destruction



Finishing  
Equipment

*We make work life more  
productive and secure*



MARTIN YALE  
Industries

### Strong Brands Build Strong Business

Martin Yale Industries, Inc. has been providing quality products to the office, graphics, industrial and school channels for over 60 years. Our rich heritage centers around some of the most recognized brands in the industry; intimus®, martin yale®, Master Products®, Mead-Hatcher and the brand best known simply for it's colour, the "green board TM" - Premier®. This impressive line-up guarantees that customers will find the right product for their application.

*We make work life more productive and secure*

**intimus**®

The **intimus**® brand is best known for industry leading shredders. These machines are intended for the professional user who needs durable, accurate, heavy-duty data protection. If you are serious about security you need the "Serious Performance" of intimus.

 **martin yale**®

Walking into almost any office today and you will not have a hard time finding the **martin yale**® brand of mailroom equipment, finishing equipment, folding machines, or shredders. Martin Yale machines are synonymous with reliability, innovation and improved productivity. If improving efficiency and productivity is important to you and your business look to **martin yale**® for your answer.

**Premier**®  
A MARTIN YALE BRAND

Long the most recognized paper trimmer in the world, **Premier**® continues to lead the pack with style and innovation. Built on our history of trademarked "green board" guillotine trimmers, to our safety conscious rotary trimmers, to our high volume **StakCut**™ trimmers, no one comes close to our reputation and performance. **Premier**®, the market leader delivering quality, tradition and value.

**MASTER**®  
A MARTIN YALE BRAND

It seems like **Master**® as been making paper punches forever, but when you have the reputation for the "Toughest Punch" in the business your product becomes timeless. Durable, heavy-duty paper punches are what we produce everyday. A variety of offerings from innovative electric punches all the way up to our 80-sheet Mega punch; when it comes to putting holes in paper we have the answer – **Master**®, The Toughest Punch in The Business.

**Mead-Hatcher**  
A MARTIN YALE BRAND

**Mead-Hatcher**™ means style, innovation, and durability in computer accessories. From keyboard drawers, monitor and printer stands, to CPU holders under the desk, **Mead-Hatcher**™ delivers the value office professionals are looking for to improve the comfort and efficiency of their work environment.

GOING  
GREEN

**Martin Yale Industries, Inc. is dedicated to helping make America a cleaner and safer place to live.**



Professional Data Shredders



Solution for Sustainable Waste Management



Multi Media Destruction



Finishing Equipment

Product Range Page

Professional Data Shredders

- Home & Small Office Shredders 5 + 6
Office & Department Shredders 7
High Through-put Shredders 8 + 9
Large-scale Data Shredding Systems 10 + 11

Solution for Sustainable Waste Management

- Shredder with Standard Waste Bin 12
PET/UBC Bottle Shredder and Crusher 13
Packaging Material Shredder 13

Multi Media Destruction

- CD Grinder 14
Hard Disk Drive Tools - Secure Erase 15
Hard Drive Shredder 16
Degaussers 16 + 17
Disintegrators 18 + 19

Product Range Page

Finishing Equipment

- Folding Machines 20 - 22
Booklet Maker 23
Coil Binding Machine 23
Letter Openers 24 + 25
Business Card Slitters 26 + 27
Score & Perforating Machine 27
CD Insert Slitter 27
Guillotines & Paper Trimmers 28 + 29
Paper Joggers 30
Stackwagons 31
Collator 31
Padding Presses 32
Moisteners 32
Check Signing Machine 33
Express Tabber 33
Paper Punches 34 - 36
Reference Systems 37
Catalog Racks 30 + 39
Posting Trays 40
Keyboard Drawers 41
Printer Stands 42

Warranty Information 47

Decorations not included
Technical changes and colour variances reserved. 11/2011

Contact Information



800.225.5644

Regional Sales

- Dave Roman VP Commercial Sales - Ext. 237
Jim Parkinson Midwest - Ext. 231
Mel Kobernusz West Coast - Ext. 232
Larry Koenig East Coast - Ext. 233

Sales Central

- Elaine Almeda - Ext. 347
Tonia Davis - Ext. 307
Shannon Fleck - Ext. 341
Jenny Price - Ext. 315
Amanda Shepherd - Ext. 308
Lisa Miskovich - Ext. 348

Technical Support

- Steve Lengel - Ext. 322
Alex Castro - Ext. 310

# intimus<sup>®</sup> PRO

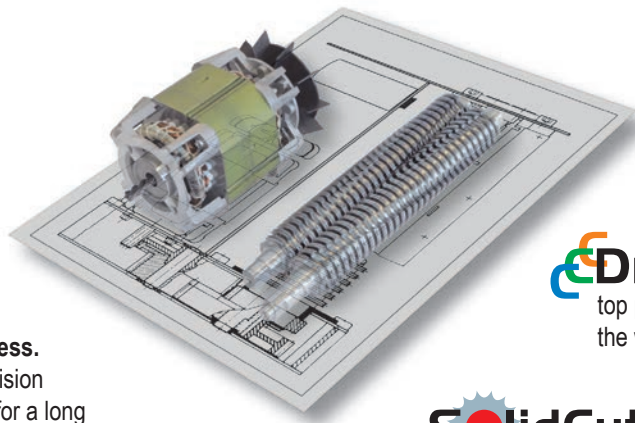

## Reliable High-performance Components

Sometimes it is the small, hidden details which ensure high operating efficiency and user-friendliness. All intimus<sup>®</sup>PRO shredders are built from durable, precision engineered, high-performance components, designed for a long life of high volume usage – and everyday use. Maintenance-free slide bearings for the cutting cylinders and capacitor motors help reduce maintenance costs and avoid machine downtime.

**eDrive**  
top performance throughout the whole life cycle

**SolidCut**  
for many years of spotless cutting results

## i-control<sup>®</sup>



**Everything under Control**  
*i-control*<sup>®</sup> is the heart of the technical concept, that controls the shredder's functions and provides a visual information centre for maximum clarity in operator guidance.



## Silentec<sup>®</sup>

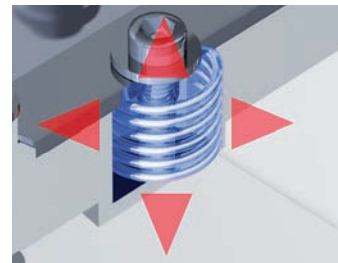

**Silent Operation**  
Shredding has never been so quiet. intimus<sup>®</sup>PRO data shredders not only rank among the most silent models in their class – courtesy of **Silentec**<sup>®</sup> – but the sound pattern is also acoustically pleasing.

## 2x2 cut.collect



**Segregate Materials**  
Rigorous separation of the systems is vital for environmentally-friendly disposal: **2x2 cut & collect** reduces the load on the cutting units and simplifies removing the shredded material with the use of a practical basket-in-basket solution.

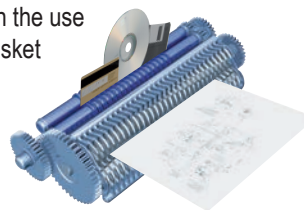

## EcoLogic

**Energy efficiency**  
intimus<sup>®</sup>PRO data shredders are equipped with the **EcoLogic** energy management system as a standard feature. Time-responsive electronics put the shredder into "sleep mode" after it has been idle for some time, automatically reducing its power usage to zero. This eliminates the extravagant power consumption of the stand-by mode.

## DLS

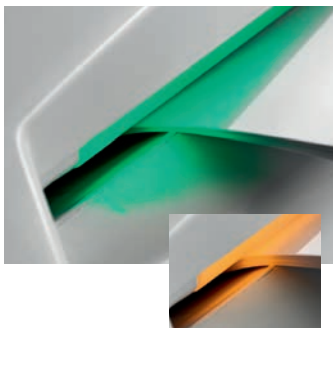

**Optimal Efficiency**  
**DLS** detects the paper volume as it is fed into the cutting unit. The result of this measurement is communicated to the user by changing colours, like traffic lights, of a light strip in the paper feed area.



...against fracture of cutting cylinders



## Home & Small Office Shredders

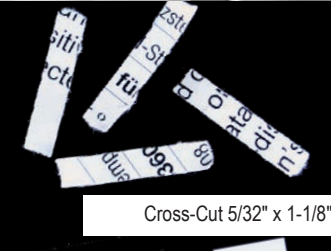

### Deleting Day-to-Day Documents

Scrap paper and documents thrown into a waste basket can contain competitive secrets and sensitive information and potentially harm your organisation if it is not disposed of properly. A personal shredder by the desk ensures total data protection wherever you work – at the office or at home. Many reasons make intimus<sup>®</sup>PRO shredders make such great desktide companions: With a compact design, they fit easily underneath a desk, and paper can easily be fed into the shredder at a low angle. No one wants to work next to a noisy office machine. To ensure a harmonious work environment, our shredders are equipped with low-noise ball bearings in the motors, creating a remarkably quiet operation sound. This allows reassurance of real security – day in and day out.

#### intimus<sup>®</sup> 20 CC3

##### ...at the desk

- Low noise level
- Automatic start/stop with light barrier
- Integrated Auto Reverse Function for easy removal of paper jams
- Removable catchbasket

Shreds additionally...



#### intimus<sup>®</sup> 26 CC3, 32 CC3

##### ...at the desk

- Low noise level
- Automatic start/stop with light barrier
- Integrated Auto Reverse Function for easy removal of paper jams
- Illuminated indicators for standby, basket full, door open and paper jam
- Removable catchbasket
- Mounted on rollers for flexible use

Shreds additionally...



	Model intimus <sup>®</sup>	20 CC3	26 CC3	32 CC3
Size of shreds	inches	5/32 x 1-1/8	5/32 x 1-1/8	5/32 x 1-1/8
Shredding capacity 70 g/m <sup>2</sup> *	sheets	8	8	12
Shredding capacity 80 g/m <sup>2</sup> *	sheets	5	7	10
Cutting speed**	ft. / min.	8	12	12
Working width	inches	9	9.5	9.5
Catch basket	volume gal.	5.28	6.9	8.5
Motor (International Voltages Available)		0.92 HP Actual, 115 V	0.92 HP Actual, 115 V	0.92 HP Actual, 115 V
Noise level	db (A)	< 55	< 55	< 55
Dimensions	W x D x H approx. inch	13.5 x 10 x 18.25	15 x 13 x 21.7	15.4 x 14.2 x 23.6
Weight	approx. lb.	18.5	35.3	41.9

\* Sheet capacities vary depending on quality, weight, grain of paper and sufficient power supply. It may be lower if the voltage is below the rated/nominal value.

\*\* Theoretical average sheets per minute.



Capacity equals amount of paper waste caused by approx. persons

## Deleting confidential Information

Every well organized, efficient office needs to protect its sensitive information. Statutory requirements and commercial considerations demand that the right shredder is chosen for each specific application. Your organisation's regulatory compliance and public reputation depend on shredding your sensitive documents down to the right particle size.

The "office class" range of intimus<sup>®</sup>PRO data shredders meets all expectations: safe and easy to use, sophisticated quiet technology, modern design and a balanced choice of performance levels and shredding capacities. Employees at all levels of your organisation will find these shredders easy to operate, with a visual information centre providing clear guidance – when the bin is open, when the bin is full, and other conditions that require attention. In addition to its durable and user-friendly design, the intimus<sup>®</sup>PRO is highly energy efficient.

**Level 6 Shredders that Meet and Exceed NSA/CSS 02-01 Specifications are also available.**



Size of shreds 5/32" x 1-13/32"



Size of shreds 5/64" x 19/32"



Size of shreds 5/32" x 1-13/16"



Size of shreds 1/8 x 1-1/2"

### intimus<sup>®</sup> 45 / 60 / 90

...in the office

- Low noise level
- Integrated Auto Reverse Function for easy removal of paper jams
- Illuminated indicators for
  - standby, basket full, door open and paper jam
- Sealed dust-free design with robust wooden cabinet
- Mounted on rollers for flexible use

Shreds additionally...



2-4

intimus<sup>®</sup> 45 CC3 / CC4



intimus<sup>®</sup> 60 CC3 / CC4

5+



intimus<sup>®</sup> 90 CC3 / CC4

5+



	Model intimus <sup>®</sup>	45 CC3	45 CC4	60 CC3	60 CC4	90 CC3	90 CC4
Size of shreds	inches	5/32 x 1-13/32	5/64 x 19/32	5/32 x 1-13/32	5/64 x 19/32	5/32 x 1-13/32	5/64 x 19/32
Shredding capacity 70 g/m <sup>2</sup> *	sheets	18	8-9	18	8-9	18	8-9
Shredding capacity 80 g/m <sup>2</sup> *	sheets	16	6	16	6	16	6
Cutting speed**	ft. / min.	16		16		16	
Working width	inches	10.25		10.25		10.25	
Catch basket	volume gal.	11.9		15.9		23.8	
Motor (International Voltages Available)		0.92 HP Actual, 115 V		0.92 HP Actual, 115 V		0.92 HP Actual, 115 V	
Noise level	db (A)	< 55		< 55		< 55	
Dimensions	W x D x H approx. inch	16.5 x 15.4 x 26		16.5 x 15.4 x 30.3		16.5 x 15.4 x 39	
Weight	approx. lb.	70.5		75		84	

\* Sheet capacities vary depending on quality, weight, grain of paper and sufficient power supply. It may be lower if the voltage is below the rated/nominal value.

\*\* Theoretical average sheets per minute.



Capacity equals amount of paper waste caused by approx. persons



## Office & Department Shredders

### intimus<sup>®</sup> 120 ...in the office

- Low noise level
- Integrated Auto Reverse Function for easy removal of paper jams
- Illuminated indicators for
  - standby,
  - basket full,
  - door open
  - and paper jam
- Sealed dust-free design with robust wooden cabinet
- Mounted on rollers for flexible use



5+

intimus<sup>®</sup> 120 CC3 / CC4

### intimus<sup>®</sup> 175 ...in the office

- Low noise level
- Automatic start/stop with light barrier
- Integrated Auto Reverse Function for easy removal of paper jams
- Illuminated indicators for
  - standby,
  - basket full,
  - door open
  - and paper jam
- Large collecting bin in dust-free enclosed cabinet
- Mounted on rollers for flexible use



10+

intimus<sup>®</sup> 175 CC3 / CC4

### intimus<sup>®</sup> 852 ...in the department

- Processes flat and crinkled paper
- Accepts the content of a full wastepaper bin
- The large hinged shelf folds down to save space when not in use. A second shelf can be added on request.
- Fully enclosed dustfree mobile base with large capacity integral catchbasket.
- The catchbasket can be pulled completely out of the shredder on a sliding frame for easy removal of the shredded material.

All models  
shreds additionally...



10+

intimus<sup>®</sup> 852 CC3

Model intimus <sup>®</sup>		120 CC3	120 CC4	175 CC3	175 CC4	852 CC3
Size of shreds	inches	5/32 x 1-13/32	5/64 x 19/32	5/32 x 1-13/16	5/64 x 19/32	1/8 x 1-1/2
Shredding capacity 70 g/m <sup>2</sup> *	sheets	23-25	15-17	up to 45	25-30	up to 80
Shredding capacity 80 g/m <sup>2</sup> *	sheets	21-23	13-15	up to 37	22-26	up to 75
Cutting speed**	ft. / min.	27	28	20	23	47-71
Working width	inches	12.25		16		17
Catch basket	volume gal.	32		46.2		54
Motor (International Voltages Available)		2.4 HP Actual, 115 V		2.5 HP Actual, 115 V		5.3 HP, 220 V/3 PH/60Hz, NEMA L 15-20 Plug
Noise level	db (A)	52		52		75
Dimensions	W x D x H approx. inch	21.3 x 15.7 x 38.6		26 x 22 x 41.375		30 x 22 x 63
Weight	approx. lb.	103.6		198		490

\* Sheet capacities vary depending on quality, weight, grain of paper and sufficient power supply. It may be lower if the voltage is below the rated/nominal value.

\*\* Theoretical average sheets per minute.



Capacity equals amount of paper waste caused by approx. persons

## At the end of the day it's power that counts.

intimus®POWER Heavy Duty Shredders have stood the test of time with decades of service as centrally positioned systems for disposing of discarded data media in accordance with data protection requirements.

**The range offers shredder models for up to 550 sheets or even complete ring binders in one go.**

The spacious feed table with integrated conveyor belt provides for controlled, fatigue-free, safe and rapid loading into the cutting mechanism.

The shredded material is collected under the cutting mechanism in large mobile or swing-out containers.



Maximum safety and performance



intimus® 14.95

### intimus® 14.95

The intimus® 14.95 Central Shredding System with Conveyor Feeding System and Paddle Sweep allows for loose and crumpled paper feeding. This unit is designed to support a central destruction area, but is narrow enough to fit thru a standard door, allowing it to be moved throughout your facility.

- Lockable On/Off safety control
- Generously sized feed table
- Manual ON/OFF control
- Auto Stop/Reverse/Restart

Shreds additionally...



**Exceedingly manoeuvrable** – thanks to an exceptionally narrow design and fitted castors, it's easy to re-locate the intimus® 14.95.



intimus® 14.87



### intimus® 14.87

Add a baler to the 14.95 central shredder and you have the intimus® 14.87.

**This unit will reduce your scrap volume by 70%.** Bales are ejected with ease at the push of a button.

- Lockable On/Off safety control
- Generously sized feed table
- Manual ON/OFF control
- Auto Stop/Reverse/Restart
- Separate feeding slot for baling of old packaging material

Shreds additionally...



	Model intimus®	14.95	14.87
Size of shreds	mm	6 x 50	6 x 50
Shredding capacity 70 g/m <sup>2</sup> *	sheets	up to 130	up to 130
	lbs./hour	750-800	750-800
Working width	inch	17.5	17.5
Motor (International Voltages Available)		10 HP Actual, 20 HP Peak, 220 V/3 PH/60 Hz, 30 Amp	10 HP Actual, 20 HP Peak, 220 V/3 PH/60 Hz, 31 Amp
Noise level	db (A)	68	68
Dimensions ( ) = with open door	W x D x H approx. inch	31(47) x 66 x 65	105(129) x 31.5 x 64.5
Weight	approx. lbs.	977	2,100

\* Sheet capacities vary depending on quality, weight, grain of paper and sufficient power supply. It may be lower if the voltage is below the rated/nominal value.



Capacity equals amount of paper waste caused by approx. persons

GOING GREEN





## High Through-put Shredders

### Shredder/Baler Combinations intimus® 14.87 / 16.50

**Optimal handling** – bales are ejected at the press of a button. Two straps ensure they are stable. Alternatively, ejection into sacks for clean, dust-free transport and weatherproof packaging.



**Multi-functional** – the baler can be additionally used for packaging volume reduction by way of a separate feed flap.



intimus® 16.50



**intimus® POWER Heavy Duty Shredders** – space-saving solutions thanks to installation next to a wall and forward/sideways removal of storage containers.

### intimus® 16.50

The intimus® 16.50 is a high performance large document shredder with a conveyor belt feed system. The paddles will hold flat or crumpled paper in place to allow for faster shredding. High cutting performance with hardened steel cutting cylinders and a high power, thermally protected geared electric motor and stable drive. This model makes it more economical to have in one "Central" location. There will be no reason to have expired / sensitive data just laying around waiting to be shredded with this machine around.

Shreds additionally...



...also available with a baler system



	Model intimus®	16.50-11.8	16.50-11.8CC	16.50-7.8	16.50-7.8CC
Size of shreds	inch	15/32, Strip-Cut	1/2 x 2, Cross-Cut	5/16, Strip-Cut	5/16 x 2, Cross-Cut
Shredding capacity 70 g/m <sup>2</sup> *	sheets	450-500	350-420	450-550	350-420
	lbs./hour	1,800	1,800	1,800	1,500
Working width	inch	19.685	19.685	19.685	19.685
Motor (International Voltages Available)		10 HP Actual, 20 HP Peak, 220 V/3 PH/60 Hz, 31 Amp	10 HP Actual, 20 HP Peak, 220 V/3 PH/60 Hz, 31 Amp	10 HP Actual, 20 HP Peak, 220 V/3 PH/60 Hz, 31 Amp	10 HP Actual, 20 HP Peak, 220 V/3 PH/60 Hz, 31 Amp
Noise level	db (A)	74	74	74	74
Dimensions	W x D x H approx. inch	47.25 x 76.75 x 61	47.25 x 76.75 x 61	47.25 x 76.75 x 61	47.25 x 76.75 x 61
Weight	approx. lbs.	1,600	1,600	1,600	1,600

\* Sheet capacities vary depending on quality, weight, grain of paper and sufficient power supply. It may be lower if the voltage is below the rated/nominal value.



Capacity equals amount of paper waste caused by approx. persons

# VZ / VZM Series Shredder Systems...



## ...a modular System with Flexibility and High Performance

... high through-put volumes of  
600 to 2,000 kg per hour with minimal  
energy consumption

... Security level 3 or 4 per  
DIN 32757-1 with certificate

... minimal personnel requirements thanks  
to fully automated operation

**intimus**<sup>®</sup> POWER

GOING  
GREEN

- ❶ Material feed
- ❷ Pre-shredder
- ❸ Magnetic separator
- ❹ Security cutting system
- ❺ Conveyor technology
- ❻ Storage and compacting
- ❼ Air purification equipment



### Expandable controls – Extremely easy operation

All system functions are monitored and controlled by a micro-computer in a fully automated fashion. Upstream and downstream devices can also be subsequently integrated into the controls with minimal effort. This will assure maximum process reliability of the entire system and efficient adaptation to prevailing operating conditions.

## VZ / VZM Series 17.00



Continuous feed

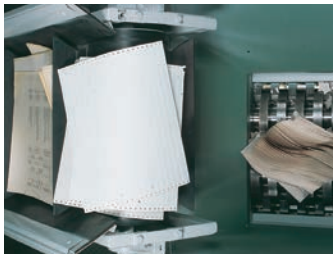

Stage 1: Pre-shredding



Integrated conveyor belt



VZM series:  
With integrated magnetic separator



### intimus<sup>®</sup> VZ17.00 / VZM17.00

This system shreds large quantities of waste material automatically. Conveyor belt serves as a waste metering device, ensuring uninterrupted throughput with large capacity hopper for continuous feeding, system is fully integrated with simple controls, automatic reverse and restart in the unlikely case of overload, compact construction with small footprint.

**Dust extractor available as an option, can be integrated with existing feed and delivery systems.**

	Model intimus <sup>®</sup>	VZ 17.00	intimus <sup>®</sup> VZM 17.00
Size of shreds	inch	1/4 x 9/16-2 Variable-Cut	1/4 x 9/16-2 Variable-Cut
Actual throughput*	lbs./hour	1,500	1,500
Working width	inch	19-11/16	19-11/16
Motor (International Voltages Available)		10 HP Actual, 20 HP Peak, 220 V/3 PH/60 Hz, 31 Amp	10 HP Actual, 20 HP Peak, 220 V/3 PH/60 Hz, 31 Amp
Dimensions**	W x D x H approx. inch	38.3 x 256 x 105.5	45 x 295 x 122
Weight	approx. lbs.	5,512	5,765

\* Values ascertained with new cutting systems, depends upon material to be shredded, supply power and feed system

\*\* with standard feed conveyor

Shreds additionally...



Stage 2: Security shredder



Outstanding ease of maintenance





Many organisations today are increasingly concerned about the environmental impact of their daily operations – everything from paper shredding to recycling bottles and cans can make a difference in the profitability and public reputation of a company.

As government regulations and public interest groups continue to demand higher standards for recycling, smart organisations are taking measures to simplify their recycling processes, reduce their recycling expenses, and help achieve more sustainable practices to preserve resources for future generations.

intimus®RECYCLE offers a full suite of solutions engineered to improve the efficiency and cost-effectiveness of any organisation's recycling practices – for paper, plastic bottles, tin or aluminium cans, and corrugated cardboard packaging.

**GOING GREEN**

Preserve Nature's Resources for future Generations – embrace Recycling



Combining Security & Waste Management

**Shredding with recycling in mind**

**intimus® 315 CC3**

The intimus® 315 CC3 is the first shredder to combine the goals and processes of sustainable waste paper management and information security. It offers an easy-to-empty solution by combining a shredder with a wheeled standard waste bin. The result is a continuous flow: from shredding over collection to recycling. At the same time control of the data elimination process remains 100% in-house. No critical information leaves the organization without first being shredded. **Collecting Bin included.**



intimus® 315 CC3

- First in combining information security and waste management
- Standard wheelie bin slides directly beneath the shredding head
- Replaces most shredding service solutions

Shreds additionally...

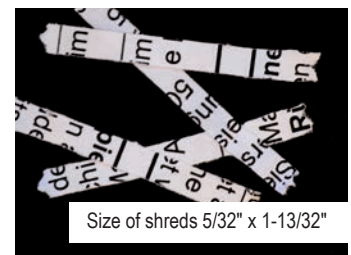

Size of shreds 5/32" x 1-13/32"

	Model intimus®	315 CC3
Size of shreds	inch	5/32 x 1-13/32
Shredding capacity 70 g/m <sup>2</sup> *	sheets	23-25
Working width	inch	12-1/4
Catch basket	volume gal.	65
Motor (International Voltages Available)		2.41 HP Actual, 115 V
Noise level	db (A)	57
Dimensions	W x D x H approx. inch	31 x 36.6 x 51.2
Weight	approx. lbs.	161

\* Sheet capacities vary depending on quality, weight, grain of paper and sufficient power supply. It may be lower if the voltage is below the rated/nominal value.



Capacity equals amount of paper waste caused by approx. persons



Used Beverage Container Compacting System

Less volume means less transportation cost

**intimus® 529**

The PET/UBC Compactor intimus® 529 is used wherever large quantities of used plastic bottles, tin or aluminum cans need to be compacted for economic disposal and transport, our machine provide for maximum volume reduction and – where applicable – for secure destruction of refund seals or coupons. Another application is processing of sub-standard products in the beverage industry or treatment of products in plastics bottles.

- Large feed hopper
- Economic and fast processing
- Proven keypad with start, stop and reverse buttons



intimus® 529

200+



Model intimus®		529
Max. diameter bottles/cans	inch	2.2 up to 5.5
Max. length bottles/cans	inch	2.95 up to 15.75
Throughput cans	lbs./hour	661
Throughput PE bottles	lbs./hour	540
Feed opening size	inch	53.4 x 31.3
Working width	inch	16
Power consumption / Power supply		3.9 kW / 230 V, 2.95 HP
Noise level (idling/load)	db (A)	57 / 88
Dimensions	W x D x H approx. inch	53.5 x 31.5 x 75.6
Weight	approx. lbs.	600



Space-filling packaging material on demand

New uses for old cardboards

**PacMaster™**

The PacMaster™ is economical and reliable! It converts empty corrugated boxes, which cost money to dispose of, into FREE large-volume filler material suitable for packing even sensitive goods for transport. Best of all – It's Easy To Use. The working surface has standard size guides marked on it so that accurate cutting is guaranteed. With one pass of the corrugated the excess is trimmed off and the packaging material is formed.



PacMaster™

- The mat shredder cuts cardboard boxes to the required size and removes any stapled or untidy edges
- Lockable power switch is also an emergency stop switch – interlocked against unauthorised use
- Size guide on the work surface ensures accurate cutting of the cardboard to customise the stuffing mats to parcel size
- Mounted on rollers for flexible use



	Model	PacMaster™
Pad grid	inch	5/32 x 4-3/8, Grid-Cut
Shredding capacity	Cartons	2-3 layers (2-ply corrugated)
Shredding capacity	m <sup>3</sup> /hour	5-7 <sup>1</sup>
Cutter feed width	inch	16-3/4
Cutter feed height	inch	0.6
Motor		220 V, 3 PH, 60 Hz
Noise level	db (A)	68.5 <sup>2</sup>
Dimensions	W x D x H approx. inch	18.75 x 27.25 x 39
Weight	approx. lbs.	386

<sup>1</sup> pre-processed material  
<sup>2</sup> during operation – at idle 62 db (A)



## Multi Media Destruction Equipment

### CD Grinder intimus<sup>®</sup> 005S

The intimus<sup>®</sup> 005S deploys the patented DATAgrind™ technology manufactured by CD Rom Inc. (listed as the DX-CD2), which grinds the data layer on any optical media down to 250 microns - beyond the point of forensic recovery in less than one minute.

All that remains is a fine dust that is collected by the built-in vacuum system. Intimus<sup>®</sup> 005S is flexible to use and easy to operate.

CDs can be processed in only one step. After grinding, the remains of the discs are recyclable as Polycarbonate. Lightweight and simple to operate. Handles up to 200 CDs per hour. Comes with three spare bags and a spare grinder wheel and DVD cutter.

- Fast, safe and complete erasure
- Simple one-button operation
- Suitable for CD, DVD and Blu-Ray Disks



intimus<sup>®</sup> 005S

### Meets NSA/CSS 04-2 requirements for CD Destruction

	Model intimus <sup>®</sup>	005S
Size of shreds		Dust
Grinding depth	microns	250
Operation time per disc	sec.	< 18
Power supply	Volt	120
Dimensions	W x D x H approx. inch	10.24 x 9.06 x 4.33
Weight	approx. lbs.	5.5

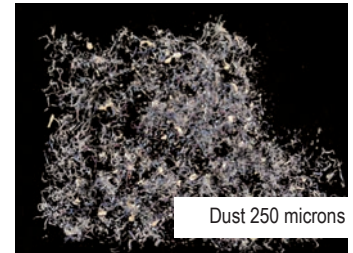

The built-in evacuating system clears away the dust particles - keeping the office clean

The DVD splitter is part of the standard equipment



## Hard Disk Drive Tool



intimus<sup>®</sup> Hammer SE



### Secure Erase intimus<sup>®</sup> Hammer SE

The intimus<sup>®</sup> Hammer SE securely erases SATA/PATA drives, HPA's, DCO's, G List, verifies erasure, and locks the drive until the process is finished. Erases up to four drives at once.

The Hammer SE device INITIATES SECURITY ERASE protocols providing guaranteed erasure of all data. User friendly interface with on-screen commands.

P.C. convertibility for transfer of erasure log/audit trail. ONCE ERASURE IS COMPLETE HARD DRIVES CAN BE REUSED making this a very ECO friendly product.

Meets NIST 800-36 and 800-88



intimus<sup>®</sup> Hammer SCSI

### Secure Erase intimus<sup>®</sup> Hammer SCSI

The intimus<sup>®</sup> Hammer SCSI is designed for users of SCSI drives and can handle up to thirty drives while still in their cabinets. Operates at 5.0 GB/minute and has an option for 80 pin configuration.

The Hammer SCSI includes all of the same features as the Hammer SE and ONCE ERASURE IS COMPLETE HARD DRIVES CAN BE REUSED making this a very ECO friendly product.

Coming Soon, the Sledge Hammer...option will expand the Hammers capacity to 32 drives, with HOT SWAP capabilities at up to 6.0 GB /min.

	Model intimus <sup>®</sup>	Hammer SE	Hammer SCSI
Drive interfaces		Parallel ATA (PATA) Serial ATA (SATA)	SCSI 50 pin (2) SCSI 68 pin (2)
Host interface		USB 2.0	USB 2.0
Max. transfer rate		up to 4.0 GB / minute	-
Input voltage		+ 12 VDC	+ 12 VDC
Max. input current		3.5 A	3.5 A
Voltage to drives		+ 12 VDC, 5+ VDC	+ 12 VDC, 5+ VDC
Device addressing support		28 bit & 48 bit supported	-
Max. transfer mode		UDMA mode 4	-
Supported devices		ATA 4 through ATA 7	SCSI
Dimensions	W x D x H approx. inch	4.16 x 4.15 x 1.41	4.16 x 5.18 x 1.41
Weight	approx. oz.	11	11

- Hard drives may be re-used – promoting better environmental stewardship
- Verifies that the data has been removed
- Generates a stored or printed audit trail
- Useable as a stand-alone device or in connection with any standard PC (via USB)
- Portable, stand-alone device delivers additional functionality when used with the CPR Toolbox software application (included).



## Hard Drive Shredder & Degausser

### Hard Drive Shredder intimus<sup>®</sup> Terminator DMD1001

The Terminator DMD1001 will handle all your Multimedia destruction needs and do it in an office environment. Hard Drives, CDs, Cell phones, PDAs, back up tapes and much more.

This unique unit is the only Hard Drive shredder in the market place that will plug into a standard office wall socket and its industrial casters and small foot print allows it to be moved from department to department.

Unlike competitive units it truly will do a standard HDD not just a lap-top drive and won't require costly maintenance after sixty days due to excessive build up of magnets and material in the cutting chamber.

Our unit by itself weighs almost 300 lbs. more than the competitive model.

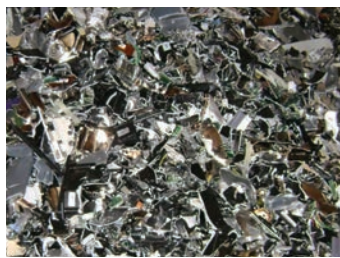

Converts Hard Drives into SCRAP



Easy to use controls



intimus<sup>®</sup> Terminator DMD1001

Model intimus <sup>®</sup>		Terminator DMD1001
Electrical		1 HP
Power Requirements		115 V, 1 PH, 60 Hz
Feed Opening	inch	1-1/2 x 4-1/2
Throughput		up to 500 HDD/hr
Shaft Diameter	inch	2-7/16
Cutter Thickness	inch	1-3/8
Dimensions	W x D x H approx. inch	44 x 24 x 48
Weight	approx. lbs.	1,000

### Degausser intimus<sup>®</sup> T4W1 Degausser

The intimus<sup>®</sup> T4W1 manufactured by Proton Inc. is engineered to provide robust degaussing features for hard drive media up to 5,000 Oe and tape media up to 2,800 Oe. These are the maximum media coercivities available today and the maximum coercivity available for NSA test purposes.

The Proton T-4 actually produces 40,000 gauss uniform fields (4 Tesla) and usual NSA requirements are three times the flux versus media coercivity. If this general requirement is extrapolated, the Proton T-4 with 4 Tesla should reliably degauss media with a coercivity of 13,330 Oe.

In simple terms, the Proton T-4 will not be outdated soon and will degauss your magnetic media for many years to come. No other degausser compares. Destruction of confidential, sensitive and classified data is in accordance with recognized standards and provides compliance under FACTA, HIPAA, GLB, DPA, etc..



intimus<sup>®</sup> T4W1



- There is minimal training required to use this machine
- Deployment kit option available
- Five year warranty

**Meets NSA/CSS EPL-9-12A-E**





## Digital storage needs maximum protection.

With high storage capacities and many different types of information stored together, digital media are vulnerable to all kinds of abuse. Modern hard disk drives or magnetic storage tapes such as LTO or QIC can contain millions of written pages, together with other confidential information like pictures, films, financial calculations or banking data.

All of this information is typically secured during use. But after the information is no longer in use, merely deleting all the files does not solve the problem. Most deleted information can easily be restored. Spot tests made on disposed computers and hard disk drives showed that more than 80% of all tested hard disk drives had never been deleted and still contained personal data – and worse, roughly 50% of this data was hazardous.



intimus® 9000

### Degausser intimus® 9000

- Fast, safe and complete erasure in only one go
- Push button or auto-operation with door activated auto feed
- PCS (Pulse Confirmation System) – audio and visual verification of degauss
- Continuous duty, no cooling cycles necessary
- Clear indication of the operating status with indicator lights and sounds
- Portable with two integrated handles
- Very low magnetic influence to surrounding area
- Meets German standard DIN 33 858 for degaussers



intimus® 8000

### Degausser intimus® 8000

With its compact dimensions, quiet operation and a 60 second cycle time, the intimus® 8000 can fit right on a desktop.

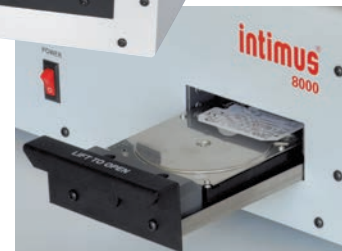

Degausser Model intimus®	T4W1	8000	9000
Magnetic Field Intensity	up to 13,330 Oe	7,300 Oe	9,000 Oe
Magnetic Flux Density	40,000 G	8,500 Oe	9,000 Oe
Erasure Cycle Time	< 1 minute	60 second	12 second
Tape & non-HDD Media Capacity	All dimensionally within		
	inch	1 x 6 x 4.3	1 x 6 x 4.3
Duty Cycle	Continuous	Continuous	Continuous
Power / Amps	8 @ 120 Volts, 4 @ 240 Volts	120 V	120 V
Dimensions	W x D x H approx. inch	13 x 17.5 x 7.375	12.25 x 13.125 x 18.75
Weight	approx. lbs.	128	68



## Disintegrators



intimus<sup>®</sup> 200/410

**NSA approval pending**

### intimus<sup>®</sup> Disintegrators

The rotors of intimus<sup>®</sup> Disintegrators are CNC-milled from solid stock. They are optimized for the processing of massive piles of material like bank note bundles and wrappers or thick stacks of printed sheets by use of specially designed bolted knives.

All of our disintegrators use the unique "Diagonal Cut" technology, which offers advantages over other knife layouts. Benefits include: automatic feeding by the knives themselves, smooth operation, minimum dust content of the mill charge and very low power consumption. The rotor knives do not need to be adjusted and are simply fixed adjacent to the bed stop.

By positioning the two solid knives, the accurate gap between rotating and solid knives is adjusted. All knives are made from tooling steel, hardened, long-lived and can be easily re-sharpened multiple times with no need for special appliances.

- Large and solid bearings, externally mounted
- Wide opening milling chamber for perfect access to all knives and fast and convenient adjustment or exchange of knives
- Easy access to the milling chamber, can be opened without tools, easy to clean, secured with safety interlock

#### Rack

- Equipped with a feed tunnel from sheet steel with sound insulation, two rubber curtains, and two fixed and two guide rollers for easy transportation. Guide rollers are lockable. Belt guard from sheet steel.



4 mm / Floppy disk

2 mm / Paper



Disintegrators Model intimus <sup>®</sup>		200/410	260/410
Throughput	kg/h at 4 mm	approx. 150	approx. 250
Feed opening size	inches	16 x 8	16 x 8
Power consumption	kW	7.5	11
Motor		7.5 kW thermo protected 220 V, 3 PH, 60 Hz	11 kW thermo protected 220 V, 3 PH, 60 Hz
Number of blades	rotor / bed	5 / 2	5 / 2
Knife layout		single plus dual "Diagonal Cut"	single plus dual "Diagonal Cut"
Noise level	db (A)	< 80	< 80
Dimensions	W x D x H approx. inch	34.6 x 45.3 x 58.5	34.6 x 45.3 x 58.5
Weight	approx. lbs.	1,351	1,700



Meets  
**ALL**  
requirements  
of...

- NSA/CSS 02-02 Paper Destruction
- NSA/CSS 04-02 Optical Media Destruction
- NSA/CSS 04-01 Key Tape Destruction

**COMES STANDARD WITH SPARE SET OF KNIVES AND 5 CASES OF WASTE BAGS**

- Air system dual bagging 3 HP
- Self cleaning filter cartridges
- 60 gallons of collection
- Integrated sound enclosure
- Includes sound proof hopper and base
- easy service access
- Heavy-duty bearings
- TEFC

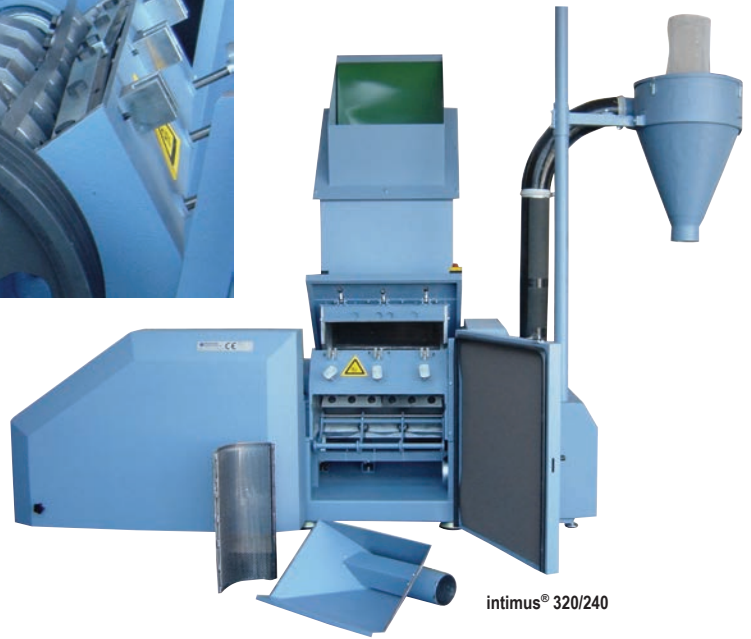

**Disintegrator intimus® 320/420**

- integrated sound package vs. box enclosures providing better access without having to move the machine - you get a smaller footprint with no additional installation costs, and no degrees heat build up
- adjustable rotor knives providing constant distance between the rotating knives and the security screen, reducing dust and keeping a consistent feed rate between knife changes
- competitive units in the market as their knives are sharpened the distance between the knife and the screen grows allowing for more build up of materials on top of the screen
- our knives are done in a fixture outside of the machine after they are sharpened and ready to be installed - this greatly shortens the time for a knife change and is much more safer than competitive models
- our knives have twice the amount of sharpening than any other units in the Market Place because we offer 3/4" grinding surface  
**...A HUGE VALUE OVER THE LIFE OF THE UNIT**
- our unit comes standard with a 3 horse power air system vs. 3/4 horse power by other units
- all access points with our unit have our patented non-tamper proof limited switches making it the safest Disintegrator - others use old style push button style

Disintegrator Model intimus®		320/420
Capacity		800DoD or up to 1200 official use
Feed Opening	inch	16 x 15
Destruction Chamber	inch	13.7 x 16.5
Blade Cutting System		3 rotors / 3 / bed
Power Consumption		22kW (30Hp), 3-phase motor, type B3, protection IP 44, 460V, 60Hz, 1800 rpm
Dimensions	W x D x H approx. inch	42 x 47 x 78
Weight	approx. lbs.	2,700

...these are just a few of the intimus® differences, give us a call today and we will be glad to discuss our products in more detail!



# Professional Paper Folding Machines

## martin yale® 1611 & 1711

Easy to use high speed folding machines for large mailrooms, associations and offices. Automatic feeding, folding and stacking of documents. User-friendly thanks to removable fold tables, easy access to rollers and self-centered paper guides. Offers an enhanced precision paper skew adjustment to keep folds crisp and accurate. Will even fold stapled sets up to 5 sheets.



**martin yale® 1611**  
 Manual set-up of fold tables: incredibly easy through straightforward display.

**Fold types including:**  
 1 2 3 4 7

## martin yale® 1812 & 2051

is a variable speed folding machine. One of the largest advantages of variable speed is that you can switch from one paper weight to another without making any adjustments – saving time between fold jobs. The fold tables are fully enclosed for quieter operation. Automatically shuts off when the fold job is complete.



**martin yale® 1812**  
 Straightforward display for manual fold and speed selection.

**Fold types including:**  
 1 2 3 4 5 6 7

## martin yale® 1711

Automatic fold type selection at the push of a button.

**Fold types including:**  
 1 2 3 4 5



## martin yale® 2051

Simplicity itself: automatic selection of fold and speed on the display.

**Fold types including:**  
 1 2 3 4 5 6 7



Model martin yale®		1611	1711	1812	2051
Capacity	sheets/h	9,000	9,000	5,000-12,000	3,000-15,000
Standard paper formats	inch	3-1/2 x 5 to 8-1/2 x 14	3-1/2 x 5 to 8-1/2 x 14	2.5 x 5.2 to 12 x 18	2.5 x 5.2 to 12 x 18
Paper weight	lb. bond to lb.index	16 to 70	16 to 70	18 to 90	18 to 90
Manual paper feed	up to sheets	5	5	4	4
Feed tray capacity	up to sheets	150	150	500	500
Motor	Volt	115	115	115	115
Dimensions	W x D x H approx. inch*	21(32.5) x 15.5 x 13.2(18)	21(32.5) x 15.5 x 13.2(18)	25(43.2) x 22.2 x 17.8(18)	25(43.2) x 22.2 x 17.8(18)
Weight	approx. lbs.	40	41	102	102

\* ( ) = in operating position



### martin yale® 1217A

The 1217A automatically feeds, folds, and collects a stack of documents from 4" x 4" to 12" x 18". It can handle paper weights from 16 lb. to 135 lb. index. A variety of folds can be created: letter, half, z-fold, and double parallel making it ideal for medium to large mailrooms. It is adjustable within a fold range of 2" and 11 1/2" on the 1st fold and 1 1/2" to 5 3/4" on the 2nd fold to allow for customized folds. The large rubber rollers provide consistent paper

feeding and a professional tight fold that emerge on durable conveyor belts creating easy-to-handle, fanned stacks. The unit operates at a speed of up to 10,300 sheets per hour.

#### Fold types including:

- 1 2 3 4



martin yale® 1217A



martin yale® Mark VII

### martin yale® Mark VII

The Martin Yale® Mark VII High Speed AutoFolder™ has a continuous feed system with manual adjust sheet separator.

The feed table has a capacity of 350 sheets of 20-lb. bond paper.

To make sure you get the fold you want there is a manual paper guide and skew adjustment.

Comes with removable cartridges for perf and/or score.

LED fold counter to help you keep track of your work.

Handles coated, laser, and copier paper types.

#### Fold types including:

- 1 2 3 4 6 7

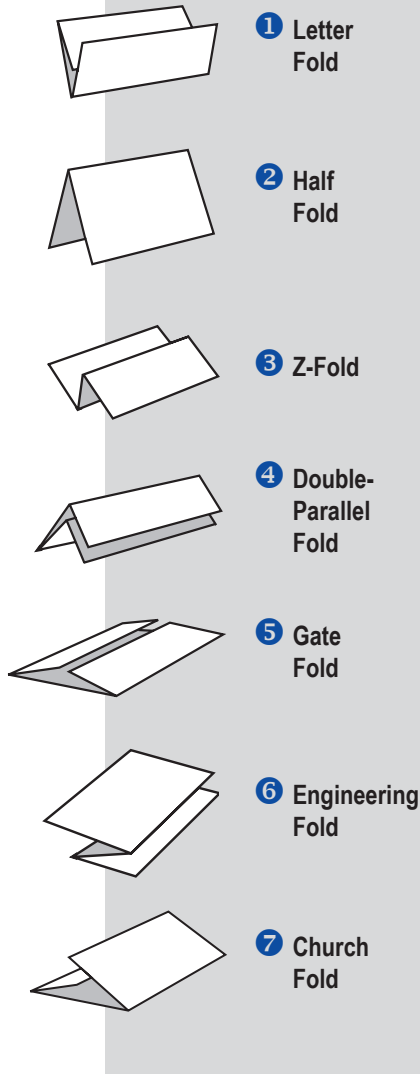

Model martin yale®		1217A	Mark VII
Capacity	sheets/h	10,300	35,000
Standard paper formats	inch	4 x 4 to 12 x 18	3.5 x 4.25 to 14 x 20
Paper weight	lb. bond to lb. index	16 to 135	16 to 80
Manual paper feed	up to sheets	5	5
Feed tray capacity	up to sheets	250	350
Motor	Volt	115	115
Dimensions	W x D x H approx. inch*	21.25(39) x 17 x 13(18)	43(50.5) x 23.5 x 14.25(19.25)
Weight	approx. lbs.	59	108

\* ( ) = in operating position

# Office Paper Folding Machines

## martin yale® P6200 & P6400

Models P6200 and P6400 are perfect for small jobs; small businesses, home offices, churches or associations. The half folded (P6400 only) or letter folded documents fit perfectly into #10 envelope. Model **P6400** easily adjusts for either letter or half fold. Model **P6200** folds into a letter fold only. Machines automatically folds paper when inserted. Hand-fed, folds 1-3 sheets and accepts stapled sets. Folds up to 36 letters a minute, 2,200 sheets an hour. Can be used with 8 1/2" X 11" paper, 16-24 lb. bond only. Easy to use and easy to remove unlikely paper jams. Has a small footprint...perfect for storing right on the desk.



## martin yale® P7200 & P7400

The P7200 and P7400 are perfect to use in smaller mailrooms, offices, churches and associations. Automatically feeds and folds a stack of documents. Each model creates four different folds: letter, half, z-fold, and double-parallel. For smaller machines, they operate at speeds of up to 4,000 sheets an hour. Model **P7200** can fold 8 1/2" X 11" and A4 paper, 16-28 lb. bond. Model **P7400** can fold 8 1/2" X 11", 8 1/2" X 14", and A4 paper, 16-28 lb. bond. The feed tray holds up to 50 sheets of paper. Folds up to 3 sheets at a time using the manual bypass, including stapled sets. Each machine includes a stacking tray for convenient folded document collection.

### Fold types including:

- ① ② ③ ④

## martin yale® 1501X

The 1501X (AKA CV-7) is great to use in large mailrooms, offices, churches, schools, businesses and associations. Automatic folds sizes from 8 1/2" X 11" and 8 1/2" X 14" paper. Creates four different fold types: letter, half, z-fold and double parallel. Operates at a speed of up to 7,500 sheets an hour and can handle sheet sizes from 31 1/2" X 5" to 83 1/4" X 14", 16-28 lb. bond. The feed table capacity of 150 sheets. Stapled sets of up to 3 sheets can be folded by hand-feeding documents into the feed table bypass.



Model martin yale®		P6200	P6400	P7200	P7400	1501X
Capacity	sheets/h	1,800	2,200	4,000	4,000	7,500
Standard paper formats	inch	8-1/2 x 11	8-1/2 x 11	8-1/2 x 11 and A4	8-1/2 x 11, 8-1/2 x 14 and A4	3-1/2 x 5 to 8-3/4 x 14
Paper weight	lb. bond to lb. bond	16 to 24	16 to 24	16 to 28	16 to 28	16 to 28
Manual paper feed	up to sheets	3	3	3	3	3
Feed tray capacity	up to sheets	N/A	N/A	50	50	150
Motor	Volt	115	115	115	115	115
Dimensions	W x D x H approx. inch*	13 x 5-3/4 x 5-7/8	14-1/4 x 6-3/4 x 7	13 x 20 x 10-1/2	13 x 20 x 10-1/2	24 x 15 x 16
Weight	approx. lbs.	10	11	17	17	23.3

\* ( ) = in operating position



## Booklet Makers

### **martin yale® BM101**

The BM101 booklet maker has dual adjustable side guides that automatically center the paper for you. It only takes seconds to set-up the machine and begin making custom booklets. Changing the paper size is quick and easy. This machine will staple and fold up to 10 sheets of 20-lb. bond. There are two staplers with four different stapling positions. Accepts paper sizes from 8 1/2" X 11" to 11" x 17", also accepts European paper sizes from B5 to A3. Requires standard staples.

Model martin yale®		BM101
Paper format	from / up to inch	11 to 17
Capacity	80 g/m <sup>2</sup> sheets	12
Booklets	up to pages	48
Staple positions / Staples Type		4 / 24/4-6
Electrical	Volt	115/60Hz
Dimensions	W x D x H approx. inch	20 x 15-3/4 x 8-1/2
Weight	approx. lbs.	34



martin yale® BM101

#### Step #1



Center the paper on the grid

#### Step #2



Bring the lever down to activate both staplers

#### Step #3



Reverse the lever to activate folder

#### Step #4



Remove finished booklet



martin yale® CB1000

Model martin yale®		CB1000
Punch Capacity	sheets	25
Electrical	Volt	115/60Hz
Dimensions	W x D x H approx. inch	14 x 17 x 7
Weight	approx. lbs.	46

## Coil Binding Machines

### **martin yale® CB1000**

Model CB1000 Electrical Coil Binding Machine is ideal for use in the professional office or copy room. The motor only runs when activated, making it very energy efficient and quiet. Punches 4 holes per inch in up to 25 sheets of paper with just the push of a button.

The vertical feed throat opening reduces the likelihood of punching mistakes making it easy to use.

Has Auto-Reverse that clears most punching jams.

This machine is filled with conveniences such as a large chip drawer with see-thru window and convenience tray with document sizing, unique coil-sizer, and organization for tools.

Built-in book-former helps align thicker books for simpler coil insertion.



## Letter Openers

martin yale® 1624



### martin yale® 1624

The 1624 is a lightweight machine that opens an envelope in seconds. It's ideal for the home office and mobile office. It automatically activates when envelope is inserted. The blades are fully enclosed to protect fingers. Has an ergonomic design to conform to the hand. Requires four AA batteries (not included).

martin yale® 1628



### martin yale® 1628

The **newest model** to the martin yale® letter opener family is the **1628 Electric Desktop Letter Opener**. Automatically feeds and opens a stack of envelopes. Accepts standard-size business envelopes. It'll handle a stack of envelopes up to 1" high. The blades are fully enclosed to protect fingers. This model will operate at a speed of up to 3,000 envelopes per hour. Offers low noise operation.



martin yale® 1616

### martin yale® 1616

The martin yale® 1616 is an ideal letter opener for small to mid-size businesses. It automatically opens envelopes when manually inserted – easy one-hand operation. Will accept standard-size business envelopes. The blades are fully enclosed to protect fingers. Non-skid rubber suction feet keep machine in place. Offers low noise operation.

	Model martin yale®	1624	1616	1628
Application area	envelopes/day	up 1	1-30	30-100
Capacity	envelopes/hr.	manual	manual	3.000
Thickness of envelope	up to inch	3/32	3/32	3/32
Height of envelope stacks	up to inch	single	single	1
Automatic paper feed		no	no	no
Cut width	inch	3/32	3/32	3/32
Electrical	Volt	battery operated	115	115
Dimensions	W x D x H approx. inch	5-1/4 x 2-3/8 x 1-3/4	9-1/2 x 7-1/4 x 4	11-1/2 x 7-3/4 x 4-3/4
Weight	approx.	4.6 oz.	3.8 lbs.	5 lbs.





martin yale® 1632

**martin yale® 1632**

The martin yale® 1632 is ideal for mid-size to large businesses. It automatically feeds and opens a stack of envelopes. Operates hands-free, just put envelopes into position and turn on. Will accept a 1-3/4" tall stack of envelopes. Accepts standard-size business envelopes. Operates at a speed of up to 7,000 envelopes/hour. The blades are fully enclosed to protect fingers. Catch tray folds for easy storage. Non-skid feet.



martin yale® 1648

**martin yale® 1648**

martin yale® offers all levels of letter openers, including the **Model 1648** that ideal for large businesses and mailrooms. It's a high-speed machine that automatically feeds and opens a stack of envelopes up to 3" tall. Operates at a speed of up to 12,000 envelopes/hour. Opens envelopes up to 1/4" thick and comes with non-skid feet so that it stays in place. The catch tray folds and can be stored in back of base unit.



martin yale® 62001

**martin yale® 62001**

Model 62001 is the largest letter opener that martin yale® offers. It's ideal for large businesses and mailrooms. For high-speed processing of large mail volumes. Automatically feeds, opens and collects a stack of envelopes. Operates at a speed of up to 17,500 envelopes/hour. Opens envelopes up to 1/4" thick and accepts a 6" tall stack of envelopes. It's adjustable width to accommodate different envelope sizes and types. Comes with removable receiving tray to take up less space when not in use.

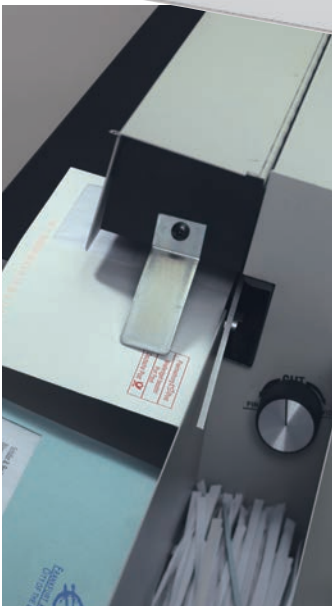

	Model martin yale®	1632	1648	62001
Application area	envelopes/day	30-500	> 100	> 500
Capacity	envelopes/hr.	7,000	12,000	17,500
Thickness of envelope	up to inch	3/16	1/4	1/4
Height of envelope stacks	up to inch	1-3/4	5	6
Automatic paper feed		yes	yes	yes
Cut width	inch	3/32	1/8	1/32 to 3/16
Electrical	Volt	115	115	115/60Hz
Dimensions	W x D x H approx. inch	13-3/4 x 10-1/2 x 5-3/4	20-1/4 x 10-1/2 x 12	35-1/2 x 10-5/8 x 12-1/8
Weight	approx.	11 lbs.	18 lbs.	41 lbs.



## Business Card Slitters

martin yale® BCS212



martin yale® BCS412



### martin yale® BCS210 & BCS212

These business card slitters easily convert 8-1/2" x 11" sheets to finished 2" x 3-1/2" professional business cards with a simple two-pass operation. The cutting blades are self-sharpening to allow for years of operation without sharpening or replacement. There are adjustable paper guides to insure accuracy. The continuous feeding will do stacks up to 5/8" thick.

**martin yale® BCS210** is a 10-up machine that cuts 8-1/2" x 11" sheets into two strips of 3-1/2" x 11" on the first pass and finishes by taking the 5-up sheets and cutting them down to 2" x 3-1/2" cards.

**martin yale® BCS212** is a 12-up machine that cuts 8-1/2" x 11" sheets into three strips of 3-1/2" x 8-1/2" on the first pass and finishes by taking the 4-up sheets and cutting them down to 2" x 3-1/2" cards.

### martin yale® BCS410 & BCS412

These business card slitters easily convert 8-1/2" x 11" sheets to finished 2" x 3-1/2" professional business cards with a simple two-pass operation. There is an extra work station for scoring and perforating. The score and perforation station is ideal for creating tent style business cards, occasion cards and tickets. The cutting blades are self-sharpening to allow for years of operation without sharpening or replacement. There are adjustable paper guides to insure accuracy. The continuous feeding will do stacks up to 5/8" thick.

The **martin yale® BCS410** is a 10-up machine that cuts 8-1/2" x 11" sheets into two strips of 3-1/2" x 11" on the first pass and finishes by taking the 5-up sheets and cutting them down to 2" x 3-1/2" professional business cards.

**martin yale® BCS412** is a 12-up version that cuts 8-1/2" x 11" sheets into three strips of 3-1/2" x 8-1/2" on the first pass and finishes by taking the 4-up sheets and creating 2" x 3-1/2" finished business cards.

Model martin yale®		BCS210	BCS212	BCS410	BCS412
Capacity	cards/min.	300	375	300	375
Printed sheet DIN A4	individual cards	10-up	12-up	10-up	12-up
Card format	inch	2 x 3-1/2	2 x 3-1/2	2 x 3-1/2	2 x 3-1/2
Creasing		no	yes	no	yes
Perforating		no	yes	no	yes
Electrical	Volt	115	115	115	115
Dimensions	W x D x H approx. inch	10-1/2 x 15 x 6	10-1/2 x 15 x 6	13 x 15 x 10-3/8	13 x 15 x 10-3/8
Weight	approx. lbs.	35	35	44	44

### **martin yale® GC210**

The martin yale® GC210 is specially designed to create business cards with a bleeding edge. Has a convenient EXTRA large waste receptacle for the scraps to help save time and clean up. Easily converts 8-1/2" x 11" sheets into finished 2" x 3-1/2" business cards with a simple two-pass operation with either full bleed or a simple no-bleed design. The cutting blades are made of hardened steel and self sharpening for years of operation without sharpening or replacement. There are adjustable paper guides that allow for easy set-up for customized needs. This machine will produce up to 360 completed cards per minute. It runs continuously feeding stacks up to 5/8" thick. Self-cleaning by the rear cover panel stripping away the waste - also works as a safety shut-off. **Comes with a CD containing prepared templates for common design programs - Quark, InDesign, Illustrator, Word and Publisher.**



	<b>Model martin yale®</b>	<b>GC210</b>
Capacity	cards/min.	360
Printed sheet	individual cards	10-up
Card format	inch	2 x 3-1/2
Electrical	Volt	115
Dimensions	W x D x H approx. inch	17 x 10-5/8 x 28-1/4
Weight	approx. lbs.	78



**martin yale® GC210**

## Score & Perforating Machine



**martin yale® SP100**



### **martin yale® SP100**

martin yale® SP100 is a score/perf machine that is a great companion for any print operation, providing stand alone score/perf capabilities. Creates tent style business cards, occasion cards, and/or tickets. Will score or perf sheets from 24 lb. bond to 100 lb. cover stock. Is fully adjustable paper guides to accommodate 3-1/2" to 12" wide sheets. Adjustable score/perf hubs that make set-up quick and easy. Includes one 14-tooth perf wheel and one scoring wheel. Additional perf, score, slit wheels are available.

	<b>Model martin yale®</b>	<b>SP100</b>
Capacity	sheets/min.	23
Sheet Size	inch	3-1/2 to 12
Electrical	Volt	115
Dimensions	W x D x H approx. inch	8 x 15 x 6
Weight	approx. lbs.	23

## CD Insert Slitter



**martin yale® CDS200**

### **martin yale® CDS200**

Model CDS200 is a CD Insert Slitter for creating the inlays that go into CD cases. Customize your CD and the CD case with this machine that slits and perforates the inlay. It easily converts 8-1/2" x 11" sheets into two CD jewel case inserts that are cut to fit and perforated along two side folds. The cutting blades are semi-self sharpening to allow for years of operation without sharpening or replacement. There are adjustable paper guides for complete accuracy. Can handle paper stock of 24 lb. bond or equivalent. Cuts and perforates up to 4,200 inserts per hour.

	<b>Model martin yale®</b>	<b>CDS200</b>
Capacity	CD inserts/min.	70
Printed sheet	individual cards	2-up
Electrical	Volt	115
Dimensions	W x D x H approx. inch	10-1/2 x 15 x 6
Weight	approx. lbs.	35



## Guillotine & Paper Trimmers



martin yale® 7000E



**martin yale® 7000E ...is a tabletop cutter ideal for small print shops**

Includes all the heavy-duty features needed to cut large stacks of paper. Will cut a stack of paper up to 12" wide and 1-1/2" thick. Other features include an adjustable back gauge, positive clamp that holds the stack in place, eliminating shifting and tearing, a heavy-duty wood base, quick crank handle, and non-skid feet. Safety blade latch prevents cutting until released.

**martin yale® 620RC ...is a 18" Manual Cutter**

Cuts a full 18 inches in length or depth and a stack up to 3.14" thick, which is approximately 800 sheets of 20-lb. bond paper. Has a precise manual back gauge, manual paper clamp that allows for additional stack pressure, a battery operated cutting line light, and an easy to assemble metal stand.

Offers standard English and metric rulers for cutting accuracy. The legs adjust up to 1-1/2" to facilitate leveling. There is a clear cover that insures safety by preventing the blade from lowering when it is in the open position.



martin yale® 620RC

Model martin yale®		7000E	620RC
Capacity	Sheets	350	800
Cutting height	inch	1-1/2	3.14
Cutting Length	inch	12	18.5
Cutting Depth	inch	12	18.7
Paper clamp		yes	yes
Dimensions	W x D x H approx. inch	20 x 30 x 16	30 x 31-1/2 x 30
Weight	approx. lbs.	45	250

**Premier® 715 & 724 ...are StakCut™ trimmers made heavy-duty with 3/4" thick wood base**

The through-hardened steel blades with precision-angle can cut stacks of up to 30 sheets. Specially made to accurately cut paper, matte board, cardboard, film, tissue, and textiles.

Each model has a permanent 1/2" grid and dual English and metric rulers. Has an ergonomic soft-grip handle for comfort for trimming. Safety precautions are covered with the patented automatic blade latch that locks with every cutting motion. Also has a finger guard to protect the entire length of the blade. Another safety feature is the torsion spring that prevents the blade from accidentally falling during operation. The hand operated clamp holds items securely for accurate cutting. Limited lifetime warranty on blades, one year on other components.



Premier® 724



Premier® 715

Model Premier®		715	724
Capacity	Sheets	30	30
Cutting Length	inch	15	24
Table size	W x D x H approx. inch	12-1/2 x 15	18-1/2 x 24
Paper clamp		yes	yes
Dimensions	W x D x H approx. inch	13-7/8 x 24-1/8 x 3-7/8	22 x 33 x 5
Weight	approx. lbs.	16	26

**Premier® Wood Series ...Guillotine trimmers made heavy-duty with 3/4" thick wood base**

The through-hardened steel blades with precision-angle can cut of up to 20 sheets at once. Accurately cuts paper, matte board, cardboard, film, tissue, and textiles.

Each model has a permanent 1/2" grid and dual English and metric rulers.

Safety features include; a patented automatic blade latch that locks with every cutting motion, finger guard to protect the entire length of the blade, and the torsion spring that prevents the blade from accidentally falling during operation.

Has a ergonomic soft-grip handle for comfort while trimming.

Model WC36 features an automatic paper clamp.

Limited lifetime warranty on blades, one year on other components.

**Premier®**  
A MARTIN YALE BRAND



Premier® Wood Series

Model Premier® W Series		W12	W15	W18	W24	W30	WC36
Capacity	Sheets	20	20	20	20	20	20
Cutting Length	inch	11-3/4	14-3/4	18	24	30	36
Table size	W x D x H approx. inch	12-1/2 x 12	12-1/2 x 15	18-1/2 x 18	18-1/2 x 24	23-1/2 x 30	23-1/2 x 36
Paper clamp		no	no	no	no	no	yes
Dimensions	W x D x H approx. inch	13-3/4 x 19 x 3-1/4	14-3/4 x 22-1/4 x 3-1/4	20-3/4 x 26-3/4 x 5	20-3/4 x 33 x 5	25 x 39 x 5-1/2	25 x 47 x 5-1/2
Weight	approx. lbs.	8	11	16	27	38	58



Premier® Poly Series



**Premier® PolyBoard™**

**...trimmers are unbreakable molded base for long life**

The self-sharpening stainless steel blade cuts up to 10 sheets at once. Has a permanent 1/4" grid and dual English and metric rulers ensure proper alignment. The Patented automatic blade latch locks with every cutting motion. Other safety features include a finger guard that protects entire blade length and a torsion spring prevents blade from accidentally falling. Has an ergonomic soft-grip handle and non-skid feet.

Model Premier® PolyBoard™		P212X	P215X	P218X
Capacity	Sheets	10	10	10
Cutting Length	inch	11-3/4	14-3/4	18
Table size	W x D x H approx. inch	12-1/2 x 12	12-1/2 x 15	18-1/2 x 18
Paper clamp		no	no	no
Dimensions	W x D x H approx. inch	12-3/8 x 19-1/2 x 2-1/4	13-3/8 x 22-1/2 x 2-1/4	13-15/16 x 26 x 3
Weight	approx. lbs.	4	4	7

**Premier® StrakCut™ Series ...are medium-duty trimmer made with a 1/2" thick wood base**

Has hardened self-sharpening stainless steel blade cuts up to 15 sheets at once. Comes with a permanent 1/2" grid and dual English and metric rulers ensure proper alignment.

Has a Patented automatic blade latch locks with every cutting motion.

Other safety features are the finger guard protects entire blade length and the torsion spring prevents blade from accidentally falling. Non-skid feet.

Model Premier® StrakCut™		T12	T15
Capacity	Sheets	15	15
Cutting Length	inch	11-3/4	14-3/4
Table size	W x D x H approx. inch	12 x 12-1/4	15 x 15-1/4
Paper clamp		no	no
Dimensions	W x D x H approx. inch	13-1/8 x 19-1/2 x 2	13-1/8 x 22-3/4 x 2
Weight	approx. lbs.	5	6

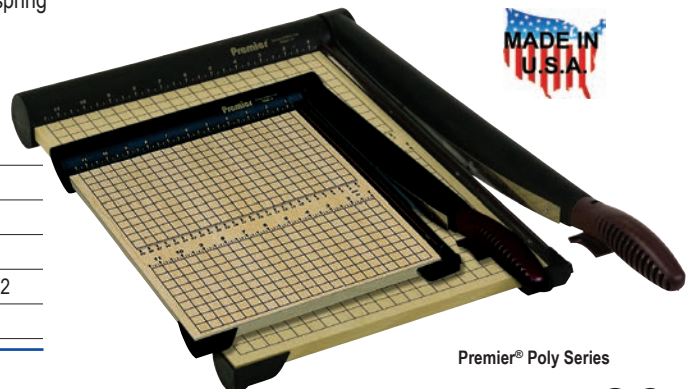

Premier® Poly Series



# Paper Joggers



**martin yale® 400**  
 The martin yale® 400 paper jogger helps eliminate static electricity and paper sticking for easier processing. It's a great companion to high speed copiers, folding machines, printing presses, cutters and binding systems. Takes up little space in your work area. Jogs 1 ream of 8-1/2" x 11" or 1/2 ream of 8-1/2" x 14" paper.

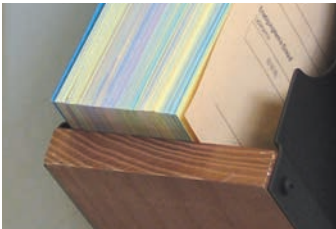

Prevents jamming which helps save time and money.



martin yale® 400



martin yale® 4200

**martin yale® 4200**  
 The martin yale® 4200 paper jogger helps eliminate static electricity and paper sticking for easier processing. It's a great companion to high speed copiers, folding machines, printing presses, cutters and binding systems. Made with heavy-gauge steel construction that holds sheets up to 17" x 22" x 3".  
 ...also has variable speed control.

Model martin yale®		400	4200
Max Sheet Size	inch	1 ream, 8-1/2 x 11 / 1/2 ream, 8-1/2 x 14	17 x 22 x 3
Electrical		115 V, 60 Hz	115 V, 60 Hz
Dimensions	W x D x H approx. inch	17.7 x 15.4 x 26	26-1/4 x 17-1/2 x 28-3/8
Weight	approx. lbs.	22	45

Over  
**50 YEARS**  
in Office  
Products



martin yale® 500

## Stackwagons



martin yale® 501

### martin yale® 500 & 501

martin yale® 500 and 501 stackwagons work great for transferring or storing large volumes of paper in mailrooms, offices, print shops, copy rooms, and more. It's designed with a center slope to ensure that paper rests against the inner stacking walls. Made from heavy-gauge steel. Some assembly required.

	Model martin yale®	500	501
Max Sheet Size	inch	8-1/2 x 11	11 x 11
Dimensions	W x D x H approx. inch	20 x 20 x 44	20 x 32 x 44
Weight	approx. lbs.	71	91

**Premier®**  
A MARTIN YALE BRAND

## Collator



Premier® CL6

### Premier® CL6

Premier® Model CL6 is a 6-Station Collator that makes it quick and easy to collate. Simply pull the lever handle to create collated sets of up to 6 sheets. Each bin holds up to 100 letter, legal or A4 size sheets. It requires no set-up, adjustment or electricity. This model is not recommended for collating existing multi-part forms or stapled sets.

	Model Premier®	CL6
Capacity	sheets/bin	100
Dimensions	W x D x H approx. inch	9-1/4 x 11-1/4 x 12-3/4
Weight	approx. lbs.	4.6



## Padding Presses



martin yale® J1811

### martin yale® J1811 & J1824

Martin Yale® J1811 and J1824 padding presses are ideal for print shops large or small. Requires simple operation that makes it easy to handle most padding jobs. Works great for carbonless forms, note pads, and scratch pads.

Has wing screws that tighten by hand – no tools necessary. There is a tip back that makes sure the paper stock is always square. Made from sturdy steel construction.

martin yale® J1824



Model martin yale®		J1811	J1824
Max Sheet Size	inch	5-3/4 x 17-3/4	19-3/4 x 17-3/4
Dimensions	W x D x H approx. inch	19 x 11 x 13	19 x 24 x 13
Weight	approx. lbs.	18	26

## Moisteners

The AquaBall™ model AQ701G has a floating ball over a reservoir of water, it's perfect for moistening your fingertips, stamps and envelopes.

The AquaPad™ model LM3 has a cellulose wick that pulls the water up from the bottom and stays moist for days. It has a special slot to slide envelopes through and a separate spot for fingertips and stamps.

Premier Moistener/Sealer All-in-One model LMS1 moistens and seals envelopes in one simple pass. No more licking and hand sealing envelopes with this little machine. It's easy to fill top access reservoir. Comes with refillable bottle and bottle storage area in side of unit. Accommodates most envelope sizes. Enclosed housing prevents splashing and evaporation.



Premier® AQ701G



Premier® LM3



Premier® LMS1



# Check Signing Machine

## Check Signing Machine martin yale® 930A

This machine is completely secure with a locking security system with a single key access – helps make sure the signature plates cannot be removed. Will sign continuous form checks and documents from 5-1/2" to 16-1/2" wide and either 3-1/2" or 7" long. Will process up to 240 documents per minute. Has easy to use registration system to keep the signatures where you want them.

**Other features include:**  
batch counter, last form shut-off, and optional tri-color ink rollers. Comes with a solid black ink roller.

**Signature plates are required for operation of this machine and must be ordered separately.**



martin yale® 930A

Model martin yale®		930A
Check Sizes	inches	5-1/2 x 16-1/2 wide / 3-1/2 or 7 long
Electrical		115V / 60Hz
Dimensions	W x D x H approx. inch	23 x 7-5/8 x 12-5/8
Weight	approx. lbs.	35

# Express Tabber

## Express Tabber martin yale® EX5100

Model EX5100 is an Express Tabber that seals mail pieces with an adhesive tab to create mailings that comply with U.S. postal requirements. It reduces cost of mailings by eliminating the need for envelopes. Will accept rolls of up to 5,000 tabs. Has precision control of tab location.

It will handle media 5" to 12" wide and up to 1/8" thick.

Processes media at up to 7,500 pieces per hour.

Accepts 15/16" and 31/32" round and 7/8" square tabs with either friction or tractor fed backing.

**Has built-in diagnostics for easy service.**

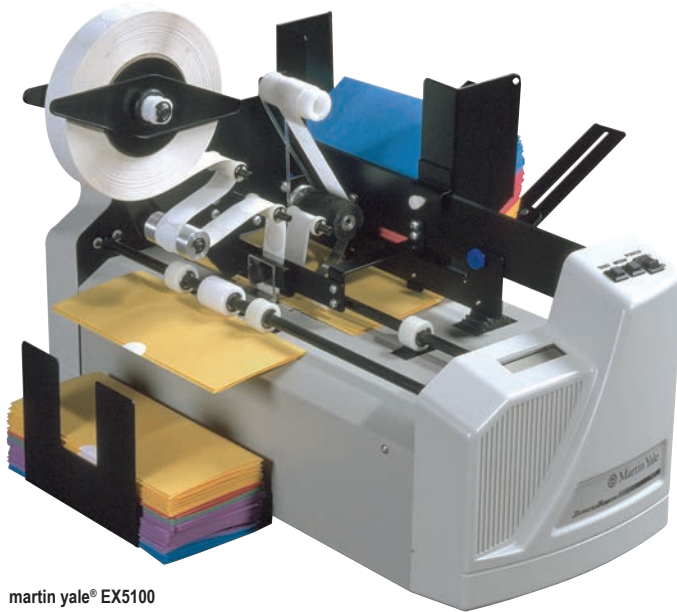

martin yale® EX5100

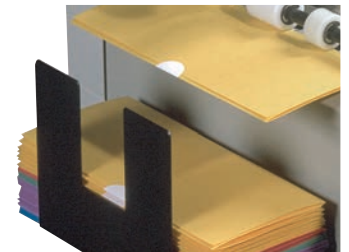

Model martin yale®		EX5100
Tab Sizes	inches	15/16, 31/32 round / 7/8 square
Electrical		115V / 60Hz
Dimensions	W x D x H approx. inch	20 x 21 x 17
Weight	approx. lbs.	40

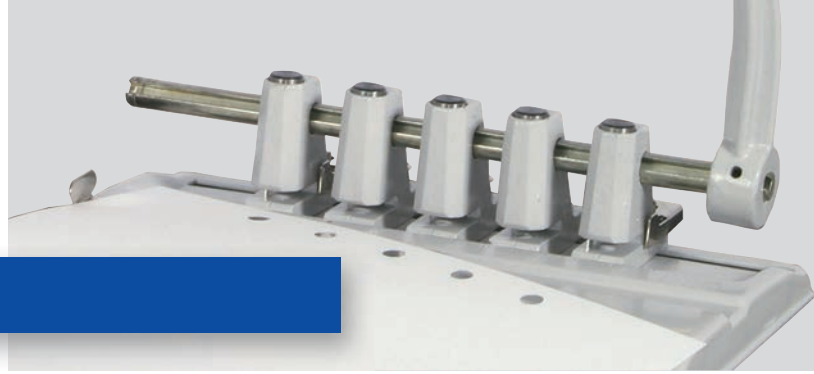

## Paper Punches

### Master® EP312 ...punches 10 sheets of paper consistently without jamming

It's designed for easy use and hand held operation if desired. Enough power to last more than one year of average use. Easy to use button on top – just push and punch effortlessly.

Punches 9/32" holes for easy page turning with less tearing.

Has an adjustable paper guide built in base, also has a large chip holder.

Operates with 6 AA batteries (not included) or 120 volt power transformer (provided).



Master® EP312

### 3-Hole Side



### 2-Hole Side

Master® EP323

### Master® EP323 ...is the Master® Duo™ Electric Paper Punch

The Master® EP323 has a compact design for desktop use and storage. The same machine will punch 2-hole or 3-hole – no adjustment needed. Has a capacity of 12 sheets – either 2 or 3 holes. One side is a dedicated 2-hole punch, while the other side is a dedicated 3-hole punch. 3,000 punch battery life.

Operates with 6 AA batteries (not included) or 120 volt power transformer (provided).

### Master® DP20

Master® Products original Duo™ punch that requires absolutely no effort to switch from 2-hole to 3-hole, model DP20. No screwdrivers needed, no thumbscrews to mess with – no adjustment required. One side is a dedicated 3-hole punch, while the other side is a dedicated 2-hole punch. Lever handles punch up to 20 sheets of 20 lb. bond paper with ease.

Punches standard 9/32" 3-hole pattern and a standard 2-hole (2-3/4" centers) pattern. Includes high-capacity chip pan. Locking handle for convenient storage. Patented design.



Master® DP20

### Master® MP3 ...punches up to 20 sheets

Has an oversized handle for easy, comfortable open-handed punching. Pre-set to punch 9/32" diameter holes to fit a standard 3-ring binder. Adjustable paper guide for easy set-up. The handle locks down for storage and safety. Large capacity paper chip pan.

Non-skid base. Made from heavy-gauge steel construction.

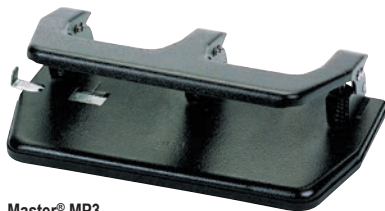

Master® MP3

### Master® MP40 ...is padded handle paper punch that punches up to 30 sheets

The soft-touch padded handle is for easier and comfortable punching. It's pre-set to punch 9/32" holes to fit a standard 3-ring binder. Handle locks down for storage and safety. Has adjustable paper guide for quick and easy set-up. Large capacity paper chip pan and a non-skid base.

Made from heavy-gauge steel construction.



Master® MP40

	Model Master®	EB312	EP323	DP20	MP3	MP40
Hole Diameter	inch	9/32	9/32	9/32	9/32	9/32
Capacity	20lb. paper/sheets	10	12	20	20	30
Dimensions	W x D x H approx. inch	11-3/8 x 3-3/4 x 2-1/8	10-1/4 x 5-1/2 x 3-1/8	10-3/4 x 5-3/8 x 4-3/4	10-3/8 x 6 x 5-1/8	10-1/2 x 6 x 5-3/4
Weight	approx. lbs.	2.2	3	7	2.7	2.8

**Master® MP50 ...punches up to 40 sheets of 20 lb. bond paper**

Has an oversized padded handle for comfortable and easy open-handed punching.  
Pre-set to punch 9/32" holes to fit a standard 3-ring binder.  
The handle locks down for storage and safety.  
Has adjustable paper guide for quick and easy set-up.  
Large capacity paper chip pan and a non-skid base.  
Made from heavy-gauge steel construction.



Master® MP50



Master® 3020B

**Master® 3020B ...one of Master® Products most popular punches**

The 3020B is an adjustable 30-sheet 2-hole or 3-hole punch.  
Ergonomically designed to provide easier paper punching.  
Punches up to 30 sheets of 20 lb. bond paper.  
The punch heads easily adjust to 11 preset positions.  
Built-in paper guide for easy set-up.  
Slide-away chip pan provides mess-free disposal of paper chips.  
Non-skid base.

**Master® 325B ...punches up to 24 sheets**

The model 325B is a lever handle paper punch that provides easier punching.  
Has adjustable punch heads for convenient 2 or 3-hole punching.  
Will accept 2 to 7 punch heads. Has an adjustable ruled paper guide ensures exact centering.  
Comes with large capacity paper chip pan and non-skid feet.  
Made from heavy-gauge steel construction.



Master® 325B

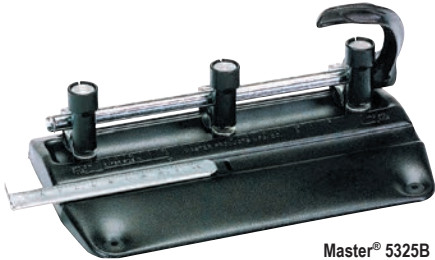

Master® 5325B

**Master® 5000 Series ...they each punch up to 32 sheets**

The 5000 Series are Lever handle paper punches that provide easier paper punching. Has adjustable punch heads for convenient 2 or 3-hole punching. Accepts 2 to 7 punch heads for any format desired. Adjustable ruled paper guide ensures exact centering. Comes with large capacity paper chip pan and non-skid feet. Made from heavy-gauge steel construction.

**Master® 525M ...punches up to 40 sheets**

Model 525M is ideal for use in hospital administrative offices, nurses' stations, doctor offices and other medical related areas. Adjustable to handle 2,3,5 or 7 hole punching, for the special forms used in the medical profession.  
Has an extra long power-handle that provides easier punching.  
Adjustable ruled paper guide ensures exact centering.  
Comes with a large capacity paper chip pan.  
Made from heavy-gauge steel.  
Comes with 5 punch heads and accepts a total of 7.

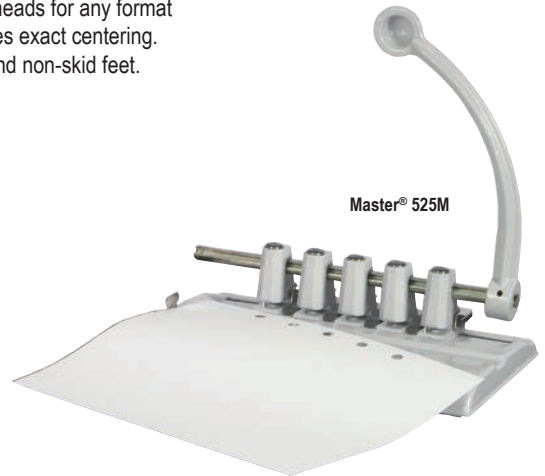

Master® 525M

Model Master®		MP50	3020B	325B	5325B	5335B	5340B	525M
Hole Diameter	inch	9/32	9/32	9/32	9/32	11/32	13/32	11/32
Capacity	sheets	40	30	24	32	32	32	40
Dimensions	W x D x H approx. inch	10-3/8 x 6 x 6-3/8	13-3/4 x 4-7/8 x 5-1/8	11 x 7-1/4 x 7	11-1/8 x 6-5/8 x 7	11-1/8 x 6-5/8 x 7	11-1/8 x 6-5/8 x 7	11 x 6-3/4 x 7-1/4
Weight	approx. lbs.	2.8	2.8	4	4.6	4.6	4.6	4

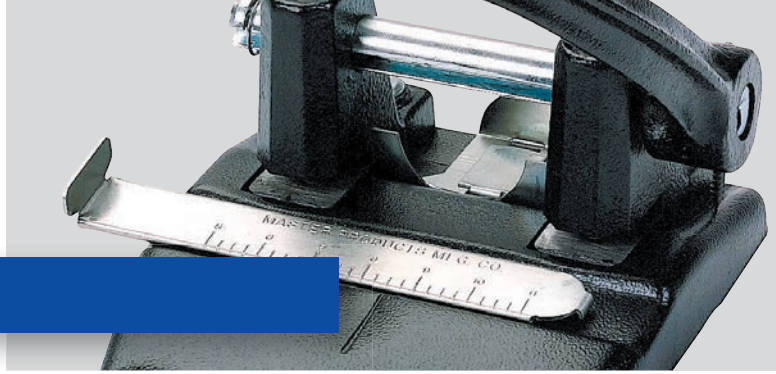

## Paper Punches

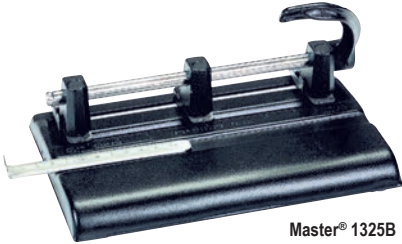

Master® 1325B

### Master® 1325B ...Lever Handle punch provides easier paper punching for up to 40 sheets

Adjustable punch heads for convenient 2 or 3-hole punching. Accepts 2 to 7 punch heads. Margin depth guides adjust for custom punching needs. Has an adjustable ruled paper guide for easy set-up. Comes with large capacity paper chip pan and non-skid rubber feet.

**Master® 1340PB ...extra long power handle that provides easier paper punching**  
 Punches up to 40 sheets of 20 lb. bond paper. Adjustable punch heads for convenient 2 or 3-hole punching. Will accept 2 to 7 punch heads for all of your custom punch needs. Margin depth guides adjust for custom punching needs. Adjustable ruled paper guide for easy set-up. Comes with a large capacity paper chip pan and non-skid rubber feet.



Master® 1340PB



Master® MP80

### Master® MP80 ...80-Sheet Mega Punch

The Master® MP80 will powerfully punch up to 80 sheets of 20 lb. bond paper. Spring-assisted mechanism and oversized handle for easier punching of large quantities of paper. It's pre-set to punch 9/32" diameter holes to fit a standard 3-ring binders. The handle locks down for storage and safety. Flip-up guards on each punch head ensure safe use and assist in alignment. Has an adjustable paper guide and large capacity chip pan. Comes with non-skid rubber feet. Replacement kit (Model MP80SET) includes 3 hollow punch pins and 6 cutting disks is also available.

### Master® EP210 ...2-Hole Electric Punch

Model EP210 can handle up to 12 sheets of 20 lb. paper, quickly and quietly. Has an automatic on/off. Punches standard 2-hole pattern (2 3/4" centers). Adjustable paper guide for the most accurate punching. Includes reverse motor de jam mechanism. Large capacity paper chip pan. Comes with AC adapter or uses 4 AA batteries (not included).



Master® EP210



Master® MP250

### Master® MP250 ...2-Hole paper punch for up to 40 sheets

It has a padded handle helps cushion hands when punching stacks. Also has an oversized 9/32" punch heads for easier page turning. Comes with an adjustable paper guide that ensures exact centering. Large capacity paper chip pan. Lock-down handle for storage and safety. Comes with a non-skid base. Made from heavy-gauge steel construction.

**Master® 3275B ...2-Hole punch with lever handle that provides easier punching**  
 The Master® 3275B is a Punches up to 40 sheets of 20 lb. bond paper. Has an adjustable ruled paper guide ensures exact centering. Comes with large capacity paper chip pan and non-skid feet. Made from heavy-gauge steel construction.



Master® 3275B

	Model Master®	1325B	1340PB	MP80	EP210	MP250	3275B
Hole Diameter	inch	9/32	13/32	9/32	1/4	9/32	9/32
Capacity	sheets	40	40	80	12	40	40
Dimensions	W x D x H approx. inch	11 x 7-1/4 x 7	11 x 7-1/2 x 11-1/8	10-1/4 x 10-1/2 x 9	4-3/4 x 5-3/4 x 3-1/2	6-3/4 x 6-1/4 x 6-1/8	5 x 6-1/8 x 6-7/8
Weight	approx. lbs.	5.8	5.15	7	1.2	1.61	2.6

# Reference Systems

**MasterView<sup>®</sup> MVMD12**

MasterView<sup>®</sup> MVMD12 is ideal for desktop quick reference of frequently used information. Use to display memos, price sheets, calendars, phone lists and more. 12 sleeves display up to 24 important documents at a time. The sleeves hold 8 1/2" X 11" and A4 size paper. Comes with a convenient note dispenser located at the base of stand (sticky note sampler included). Two-sided, non-glare and easily removable sleeves that come with index tabs.

**For replacement sleeves order MVS6.**



MasterView<sup>®</sup> MVMD12

**MasterView<sup>®</sup> MVMD24 ...High capacity – holds 48 sheets**

Model MVMD24 is the newest Desktop Reference System. Ideal for displaying memos, price sheets, calendars, phone lists, and more. Keeps all of your important documents close to your fingertips. Glare-free sleeves hold 8 1/2" x 11" and size A4 paper. Has two convenient note dispensers located at the base of the stand. Comes with sticky note samplersto get you started. Includes index tabs for your filing requirements.

**For replacement sleeves order MVS6.**



MasterView<sup>®</sup> MVMD24

**MasterView<sup>®</sup> MVSM10 ...Executive Desktop Stand**

It keeps frequently used documents at your fingertips. Has 10 sleeves display up to 20 documents at a time. The sleeves hold 8 1/2" X 11" and A4 size paper. Two-sided, non-glare and easily removable sleeves. Fully adjustable angles for desktop and countertop viewing. Included index tabs for convenient and easy filing. Made from all steel construction.

**For replacement sleeves order MVS6.**



MasterView<sup>®</sup> MVSM10

**...fully adjustable**

Model Masterview <sup>®</sup>		MVMD12	MVMD24	MVSM10
Document Size	inch	8-1/2 x 11, A4	8-1/2 x 11, A4	8-1/2 x 11, A4
Filing Capacity	Sleeves	24	48	20
Dimensions	W x D x H approx. inch	14-1/2 x 12 x 9-1/2	17 x 14-1/2 x 9-1/2	18 x 10 x 9-1/2
Weight	approx. lbs.	3.2	7	2

**MasterView<sup>™</sup> ...Reference Systems for desktop viewing of frequently used documents**

Ideal for displaying memos, price sheets, calendars, phone lists, graphs, charts and more. Angled at 60° for best desktop viewing. Non-glare sleeves offer two-sided viewing, document can be photocopied in the sleeve. Includes steel base, complete set of non-glare sleeves, and custom index kits. Holds 8 1/2" x 11" sheets. **For replacement sleeves order MVF3.**



MasterView<sup>®</sup> ML20

Model Masterview <sup>®</sup>		ML10	ML20
Document Size	inch	8-1/2 x 11	8-1/2 x 11
Filing Capacity	Sleeves	20	40
Dimensions	W x D x H approx. inch	21-1/2 x 7 x 15	27 x 7 x 15
Weight	approx. lbs.	2	3



## Catalog Racks

### Master® MVRF12 ...the Catalog Rack Retrofit Kit

Model MVRF12 adapts any Master® Catalog Rack to display single sheets of 8 1/2" x 11".

Ideal for desktop viewing of important information – including phone lists, price sheets, calendars, memos, graphs and more. Comes with non-glare sleeves offer two-sided viewing. Includes custom indexing kit, the catalog racks sold separately. Made with a heavy-gauge steel base.

Replacement sleeves are available by ordering MVF3 (set of 3 sleeves).



Master® MVRF12

### Master® MVR24 ...the Heavy-Duty System

The MVR24 can be used for desktop or countertop viewing of frequently used information – including phone lists, price sheets, calendars, memos and more.

It's compatible with all Master® Catalog Racks and accessories. Durable system ideal for viewing your documents in a variety of desktop and countertop environments. It has 24 non-glare sleeves offer two-sided viewing. This system is easy to assemble, custom indexing kit included.

Made with a heavy-gauge steel base. Holds 8 1/2" x 11" sheets.

Replacement sleeves are available by ordering MVF3 (set of 3 sleeves).



Master® MVR24

### MasterView® MVW12 ...the Wall Mount System

MasterView™ Model MVW12 is great for the use in offices, stores, factories and showrooms. Ideal for displaying memos, price sheets, calendars, phone lists, graphs, charts and more. It's angled at 15° for a better viewing angle while standing. The non-glare sleeves offer two-sided viewing, documents can be photocopied in the sleeve.

Includes steel base, 12 non-glare sleeves, and custom index kit. Mounting options include double-sided tape, screws and Velcro. Holds sheets up to 8 1/2" x 11". For replacement sleeves, order MVF3 (set of 3 sleeves).



Master® MVW12

Model Master®		MVRF12	MVR24	MVW12
Document Size	inch	8-1/2 x 11	8-1/2 x 11	8-1/2 x 11
Filing Capacity	single Sheets	24	48	24
Dimensions	W x D x H approx. inch	14 x 14 x 15	21 x 8 x 14	14 x 13 x 16
Weight	approx. lbs.	3	8	3

### Master® ...Catalog Rack Starter Sets

Master® Catalog Rack Starter Sets are complete system comes with everything needed to store and display catalogs. Hinged for fast and easy set-up. Desktop racks are angled at 45° for best viewing while seated. Countertop racks are angled at 30° for best viewing while standing. Unique tongue-and-groove system provides easy insertion and removal of sections. Heavy-gauge steel construction, available in Gray. Starter sets include a full set of 1" ring sections. Index sets are also available for these models. For replacement Index Sets order B5175M and B6125M.

Model Master®		966RS3	912RS3	66RS3
Application		Desktop	Desktop	Countertop
Filing Capacity	inch	6	12	6
Length Wing to Wing	inch	18	25	18
Dimensions	W x D x H approx. inch	8 x 10-1/2 x 8	15-1/4 x 10-1/2 x 8	8 x 10-1/2 x 5-1/2
Weight	approx. lbs.	6	8	5



Master® 912RS3G

**Master® Standard Catalog Racks**

Master® Products Standard Catalog Racks are hinged for fast and easy set-up. The desktop racks are angled at 45° for best viewing while seated and the countertop racks are angled at 30° for best viewing while standing. These racks have a unique tongue and groove system provides easy insertion and removal of sections. Made with heavy-gauge steel construction, available in Gray. Available accessories include; 1" or 2" ring sections or 1" or 2" post sections, sold separately.

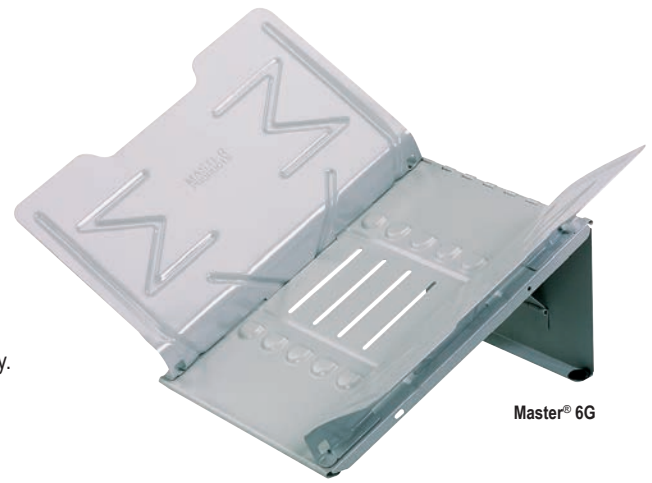

Master® 6G

	Model Master®	906G	912G	918G	6G	12G	18G
Application		Desktop	Desktop	Desktop	Countertop	Countertop	Countertop
Filing Capacity	inch	6	12	18	6	12	18
Length Wing to Wing	inch	18	25	33	18	25	33
Dimensions	W x D x H approx. inch	8 x 10-1/2 x 8	15-1/4 x 10-1/2 x 8	22 x 10-1/2 x 8	8 x 10-1/2 x 5-1/2	15-1/4 x 10-1/2 x 5-1/2	22 x 10-1/2 x 5-1/2
Weight	approx. lbs.	5.3	7.3	9.3	4.3	6.3	8.3



Master® 24G

**Master® Shielded Countertop Racks**

Master® Products Shielded Countertop Racks organizes and displays catalogs, magazines and loose-leaf materials. They are great displaying a large amount of catalogs in a compact space. Shielded for one-sided viewing only, at a 30° angle. The tongue and groove slots provide easy insertion and removal of sections. Heavy-gauge steel construction, Gray. Available accessories include; 1" or 2" ring sections or 1" or 2" post sections, sold separately.

	Model Master®	24G	30G
Application		Countertop	Countertop
Filing Capacity	inch	24	30
Length Wing to Wing	inch	40	48
Dimensions	W x D x H approx. inch	32-1/2 x 15 x 13	39-3/4 x 15 x 13
Weight	approx. lbs.	19	21

**Master® Index Set**

Master® Index Set are Ideal for protecting and organizing materials in catalog racks. The fly leaf Indexes can be used to separate and protect large sections of materials. The Index Sets include customizable tabs that are readable from both sides. Available in both 5th cut/**Model B5175M** and 6th cut/**Model B6125M**.



**Master® Catalog Rack Sections**

Master® Catalog Rack Sections are designed to securely hold catalogs and other reference materials for placement in catalog racks. Ring sections are designed for use with punched magazines and loose-leaf materials. Post sections are designed for use with larger catalogs that have drilled holes. Sections fit easily into any Master® rack with unique tongue and groove system.



Ring Section

Post Section

	Model Master®	RS3	DRS3	MPS3	DMP3
Application		Ring Section	Ring Section	Post Section	Post Section
Filing Capacity	inch	1	2	1	2
Dimensions	W x D x H approx. inch	1-1/16 x 10-1/4 x 1	2-1/4 x 10-1/4 x 1-1/2	1-1/16 x 10-1/4 x 13/16	2-1/4 x 10-1/4 x 13/16
Weight	approx. lbs.	0.3	0.5	0.3	0.5



## Posting Trays



Master® 11752

### Master® V-Matic Trays

Master® V-Matic Trays are economical and efficient filing, ideal for smaller operations. The three steel tilt plates provide sturdy support for forms. Removable tilt plates adjust to change in capacity in seconds. Made with heavy-gauge steel with durable powder coat finish.

Model Master® V-Matic Trays		11752	11756	11764
Document Size	inch	6 x 9	6 x 9	8 x 8 to 8-1/2 x 11
Dimensions	W x D x H approx. inch	14-3/4 x 6-1/2 x 8-3/4	14-3/4 x 7-3/4 x 10-3/4	14-3/4 x 9 x 11-1/4
Weight	approx. lbs.	6	7.2	8.1

**MASTER**®  
 A MARTIN YALE BRAND



Master® 11307

### Master® Card-Matic Trays

Master® Card-Matic Trays have an adjustable capacity unit for filing smaller form sizes. Front plate tilts open and closes with slight pressure on operating handle. Uniform pressure irons out wrinkles and curls on forms. Rounded carrying handles and non-slip friction strips. Made with heavy-gauge steel with durable powder coat finish.

Model Master® Card-Matic Trays		11303	11307
Document Size	inch	6 x 9	6 x 9
Dimensions	W x D x H approx. inch	12-1/8 x 6-1/2 x 8-1/2	14-5/8 x 6-1/2 x 8-1/2
Weight	approx. lbs.	5.6	6.1



Master® 11070

### Master® Porta-Matic Posting Trays

Master® Porta-Matic Posting Trays have are drop-side models that provide full length platform to presort documents. Simple up/down operating handle activates toggle hinge action. Positive action rear compressor plate permits quick changes in capacity. Full-length friction strips on tray floor prevent forms from slipping. Made with heavy-gauge steel with durable powder coat finish.

Model Master® Porta-Matic Tray		11070
Document Size	inch	8 x 8 to 8-1/2 x 11
Dimensions	W x D x H approx. inch	15 x 9-1/8 x 9-1/2
Weight	approx. lbs.	10.9

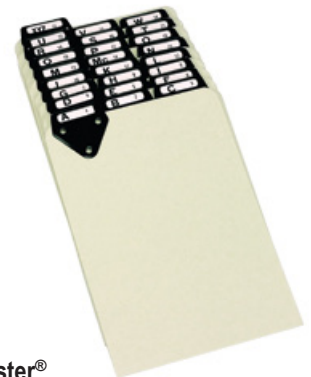

### Master® Posting Tray Index Sets

Keep forms organized with durable index sets. Each set includes A-Z inserts. Tabs are made of metal to last longer. Durable pressboard construction

Model Master® Posting Tray Index Sets		14254	14522	14880
Dimensions	W x D x H approx. inch	6 x 9	8-11/42 x 11	8 x 8



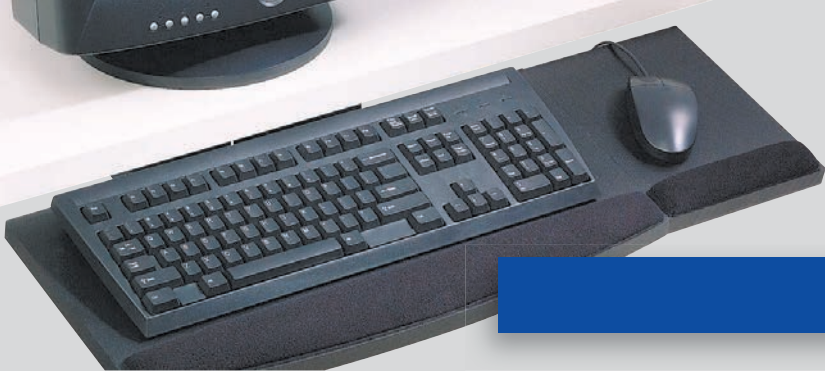

## Keyboard Drawers

### Mead-Hatcher™ Economy Steel Keyboard Drawers

Mead-Hatcher™ offer two Economy Steel Keyboard Drawers.

Model **21885** for keyboard only and Model **21028** for both keyboard and mouse.

Both extend 11" and locks into keying position. Comes with smooth-glide ball bearing slides for easy drawer pullout. Accepts standard-sized keyboards. Includes a padded wrist rest for additional comfort. Made from heavy-gauge, static-dissipating steel construction.

Model Mead-Hatcher™	21885	21028
Application	Keyboard Only	Keyboard/Mouse
Color	Pearl Gray	Pearl Gray
Dimensions W x D x H approx. inch	25-9/16 x 16-1/8 x 3-1/8	31-1/2 x 16 x 5
Weight approx. lbs.	8.8	9.8



Mead-Hatcher™ 21885

Mead-Hatcher™ 21028



Mead-Hatcher™ 22030

Mead-Hatcher™ 32030

### Mead-Hatcher™ Adjustable Steel Keyboard Drawers

Models **22030** and **32030** are Adjustable Steel Keyboard Drawers that feature a 2 1/4" height adjustment and a 15° positive/negative tilt range for individual user comfort. The drawer extends 11" and locks into keying position for hassle-free operation. Comes with smooth-glide ball bearing slides for easy drawer pullout. Includes padded wrist rest for additional comfort.

Made from heavy-gauge, static-dissipating steel construction.

Model Mead-Hatcher™	22030	32030
Application	Keyboard/Mouse	Keyboard/Mouse
Color	Pearl Gray	Black
Dimensions W x D x H approx. inch	33-1/8 x 16 x 5	33-1/8 x 16 x 5
Weight approx. lbs.	12	12

### Mead-Hatcher™ Articulating Keyboard Arm

The Mead-Hatcher™ KA150 is a Lift-N-Loc™ Articulating Keyboard Arm.

To adjust the height, just lift and move the tray. Also features a height adjustment, 360° swivel and a 30° positive/negative tilt range. Both height and tilt adjustments work in combination to help keep wrists straight while keying.

The low profile design gives more leg room. Includes soft-touch padded wrist rest for keyboard and mouse. This model has a durable spacious wood platform accepts standard and ergonomic keyboards. The mouse tray attaches on the right or left side. **Meets ANSI/BIFMA standards.**

Model Mead-Hatcher™	KA 150
Application	Stand Mount
Track Length inch	21
Color	Black
Dimensions W x D x H approx. inch	28 x 12-1/2
Weight approx. lbs.	17



Mead-Hatcher™ KA150





## Printer Stands

### Mead-Hatcher™ Printer Stands

Mead-Hatcher™ offer three different choices in printer stands.

There is the **24050** which has one extra shelf for storage, the **24060** which offers two shelves for storage and then the **24070**, which not only has two shelves for storage, but also holds a standard-size CPU.

These printer stands are great for freeing up valuable desktop space by storing the printer, paper, etc. under the desk or workstation.

Made from heavy-gauge, static-dissipating steel construction that holds a printer weighing up to 75 lbs. Accepts most sizes of laser and inkjet printers with a foot-print up to 18" w X 18" d.

The **24070** will accept a CPU up to 7-1/2" wide.

All models come with heavy-duty casters that allow the entire unit to pull out to give easy access to the cable connections. Comes with 2 built-in power strip holders in lower shelf of the unit, giving a convenient and usable outlet (power strips not included).

**Mead-Hatcher**  
 A MARTIN YALE BRAND



Mead-Hatcher™ 24060



Mead-Hatcher™ 24070



Mead-Hatcher™ 24050

	Model Mead-Hatcher™	24050	24060	24070
Application		1- shelf	2- shelf	1- shelf/CPU
Dimensions	W x D x H approx. inch	22 x 21-5/8 x 8-1/2	22 x 21-5/8 x 17-1/8	22 x 21-5/8 x 17-5/8
Weight	approx. lbs.	16	20	26





## Martin Yale Industries, Inc. General Warranty

Martin Yale Industries (MYNA) warrants all component parts and workmanship of its products to be free of manufacturing defects for a period of one year from the date of purchase by the consumer. Papermonster products carry a 90 day replacement warranty.

**Parts Coverage:** consumable parts are not covered under warranty. Consumable parts include: shred boxes, knives, cutting sticks, drill bits, paper punch pins, blocks, retarders and feed wheels. Paper trimmer blades have a limited lifetime warranty. MYNA reserves the right to repair or replace all other component parts found to be defective within the warranty period, unless failure was caused by accident, misuse, improper maintenance, or damage caused while shipping back to MYNA for warranty reasons. MYNA reserves the right to require return of defective parts. If return is required, approved warranty parts will be shipped upon request and invoices at the then prevailing rates including freight. Credit for the warranty parts will be issued, including the cost of freight to and from our factory if upon inspection, the returned parts prove to be defective. If air freight or overnights shipment is requested, the dealer or consumer will be responsible for those charges with no reimbursement.

**Labor Coverage:** MYNA retains the sole right to authorize labor to repair a machine in the field or have the machine returned to our factory for repair. If returned to our factory for repair, the dealer or consumer must contact MYNA for a Return Goods Authorization (RGA) and return the unit with transportation charges prepaid. Labor charges for the installation or replacement of consumable parts as described above, is not covered. Labor charges for routine maintenance are not covered.

**Shipping Coverage:** MYNA will not be responsible for any packaging or transportation charges incurred without its specific authorization through the RGA process. No C.O.D. shipments will be accepted. MYNA will pay shipping charges to return products back to the consumer or dealer after any authorized repair in our factory.

### Additional Martin Yale Industries Shredder Warranties

**Intimus Branded Shredders:** MYNA warrants all Intimus slot-fed shredders, except high security models, to be free of defects in material and workmanship under normal use for two years parts and labor. A lifetime limited warranty is provided for fracture of the cutting cylinders.

**Martin Yale Branded Shredders:** MYNA warrants Martin Yale shredders to be free of defects in material and workmanship under normal use for two years, parts and labor.

**Specialty and Industrial Shredders:** MYNA warrants all conveyor fed shredders, hopper fed shredders, the PacMaster, PacMate and ScriptStroyer™ shredders to be free of defects in material and workmanship under normal use for one year parts and labor. The cutting cylinders of all conveyor or hopper fed industrial capacity shredders and the PacMaster are warranted for five years for fracture of the cutting cylinders. The cutting cylinder of the Scriptstroyer is warranted for one year.

**High Security Shredders:** MYNA warrants all high security shredders to be free of defects in material and workmanship under normal use; one year parts and labor, one year on the cutting cylinders.

Warranty is null and void for any slot-fed shredders of any brand, used as part of a shred for pay service.

**Warranty procedures:** If you have a warranty claim, contact MYNA for a Return Goods Authorization (RGA). MYNA will not be responsible for any charges incurred without its specific authorization. To receive an RGA, contact Martin Yale Industries, 251 Wedcor Avenue, Wabash, IN 46992. Your request for an RGA must include the model number and serial number of the product.

### Disclaimers:

- a) This warranty applies to current models only. For discontinued models, consult original warranty.
- b) This warranty is void if repairs are necessitated by accident, misuse, abuse, water damage, or fire damage.
- c) All Repairs must be performed by an authorized technician.
- d) Modifications to, or alterations of the product, including any override of safety features or use of non MYNA approved parts will void this warranty.
- e) Particle cut, cross-cut, and high security shredders of all types and brands require lubrication and running in reverse as directed in the Operator's Manual with approved liquid (non-spray) shredding oils. Failure to lubricate these systems will void the warranty.
- f) This warranty is in lieu of all other warranties, expressed, implied, statutory or otherwise.
- g) Extended warranties are subject to the same provisions and terms as this general warranty.
- h) MYNA makes no warranty of merchantability or fitness of any product, for any particular purpose.
- i) To the extent permitted by law, any consequential or incidental damages of any kind, including, but not limited to lost profits or other economic injury are not warranted.

**INTRODUCING**



**Complete and Permanent Erasure of Information**

**Information Destruction on Hard Disk Drives**  
**Degausser intimus® 8000**

The HDD-Degausser intimus® 8000 relies on APT (Advanced Pulse Technology™). During the erase an effective quick burst generates a strong and powerful pulse. This results in 90% lower energy consumption compared to other models.

At the same time it produces an erasing field many times stronger than those produced by the read/write heads in hard drives and tape drives. The field strength of an intimus® 8000 Degausser destroys the magnetic structure and ensures that the data are no longer recoverable by computer or laboratory attacks.

...more Degaussers see page 17



intimus® 8000

**Degausser intimus® 8000**  
 With its compact dimensions, quiet operation and a 60 second cycle time, the intimus® 8000 – **can fit right on a desktop**

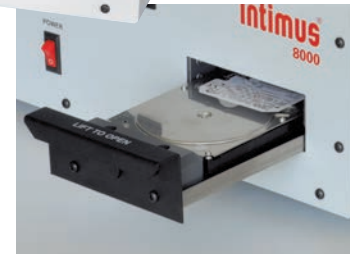

Degausser Model intimus®		8000
Magnetic Field Intensity		7,300 Oe
Magnetic Flux Density		8,500 Oe
Erase Cycle Time		60 second
Tape & non-HDD Media Capacity		All dimensionally within
	inch	1 x 6 x 4.3
Duty Cycle		Continuous
Power / Amps		120 V
Dimensions	W x D x H approx. inch	13 x 17.5 x 7.375
Weight	approx. lbs.	42



**MARTIN YALE**  
 Industries

251 Wedcor Avenue  
 Wabash, IN 46992  
 Ph: (800) 225-5644  
 Fax: (260) 563-4575  
 www.martinyale.com

PRST STD  
 US POSTAGE  
 PAID  
 WABASH, IN  
 PERMIT NO.9

- Document Shredders
- Folding Machines
- Paper Trimmers/Cutters
- Mailroom Equipment
- Finishing Equipment
- Paper Punches
- Document Management
- Ergonomic Computer Accessories